

36 CIRCLE

ICONS Regional Creations
PEOPLE The Specialists
BEYONDX Harbingers of Technology
FUTURE PROOFING Disruptive Innovation

Perspectives on design, engineering & management



EXPERIENCE
BEYOND.



ONG&ONG
group

VISION Experience Beyond

PURPOSE To Improve the World in which We Live

ROLE To Enhance the Well-being of Inhabitants through Excellence in Sustainable Design

... poised for
the tidal wave
of disruption.

Ong Tze Boon
Group Executive Chairman

Anticipating the rhythm of our built environment for future-forward creations.
Weaving a team with deep experiences dedicated to your needs,
to deliver an EXPERIENCE BEYOND.

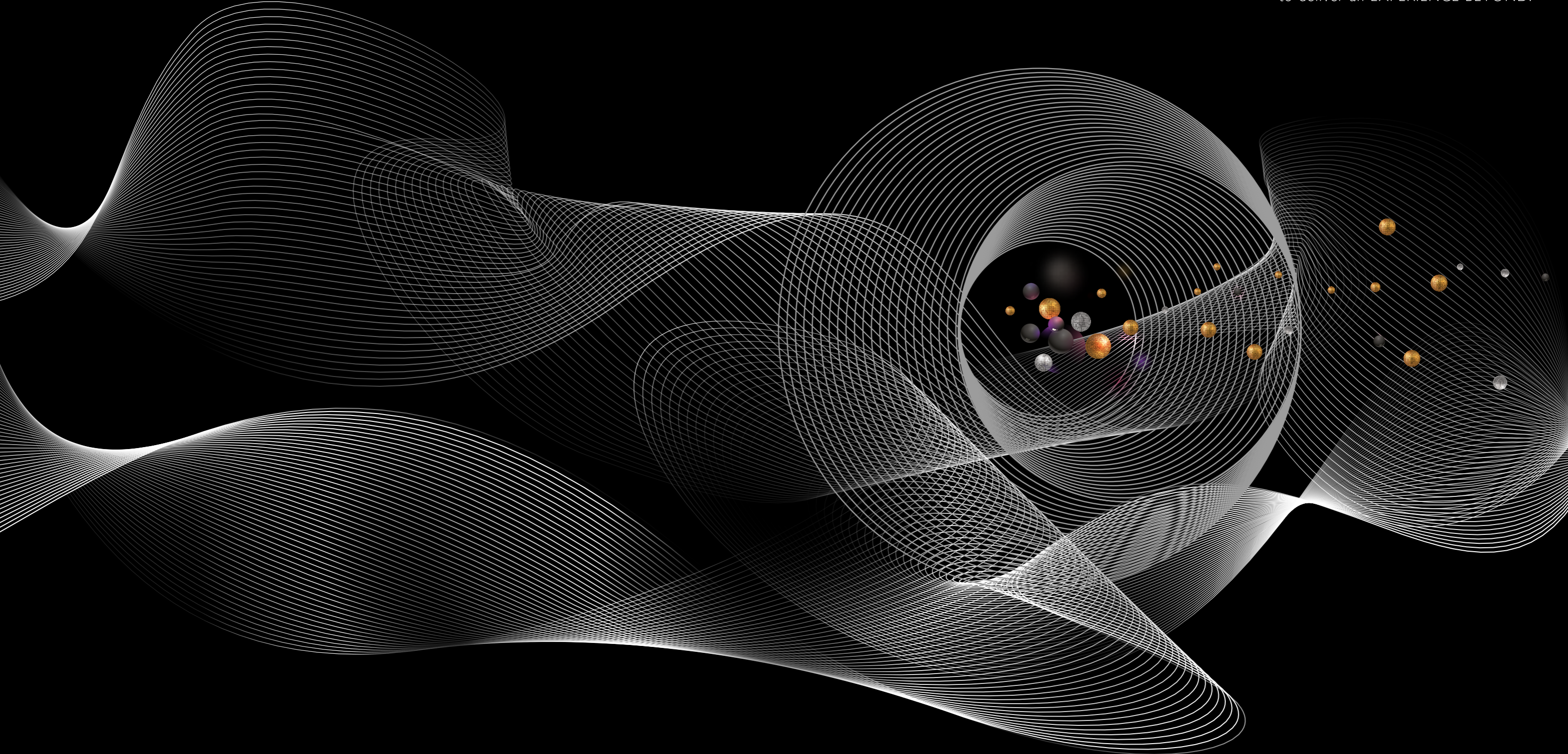

ORCHESTRATING A BESPOKE EXPERIENCE

Tekka Place

Singapore

Experience Beyond Lifestyle

An ONG&ONG Project



Experience Beyond
Untouched Territories

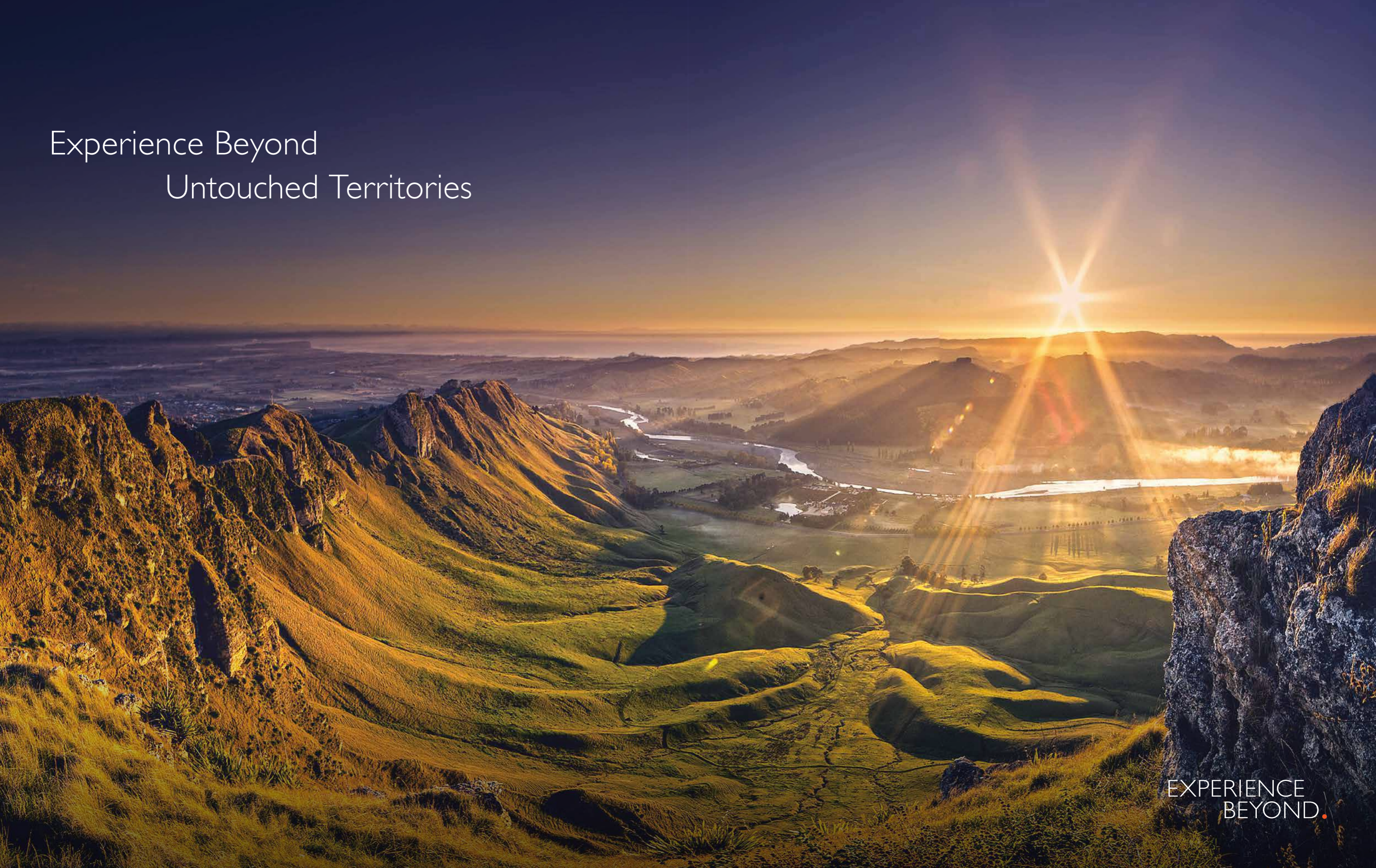

EXPERIENCE
BEYOND.

ONG&ONG PINDROPS

We are proud of our numerous ties across Asia and worldwide, bonding the ONG&ONG family, valued clients and projects.

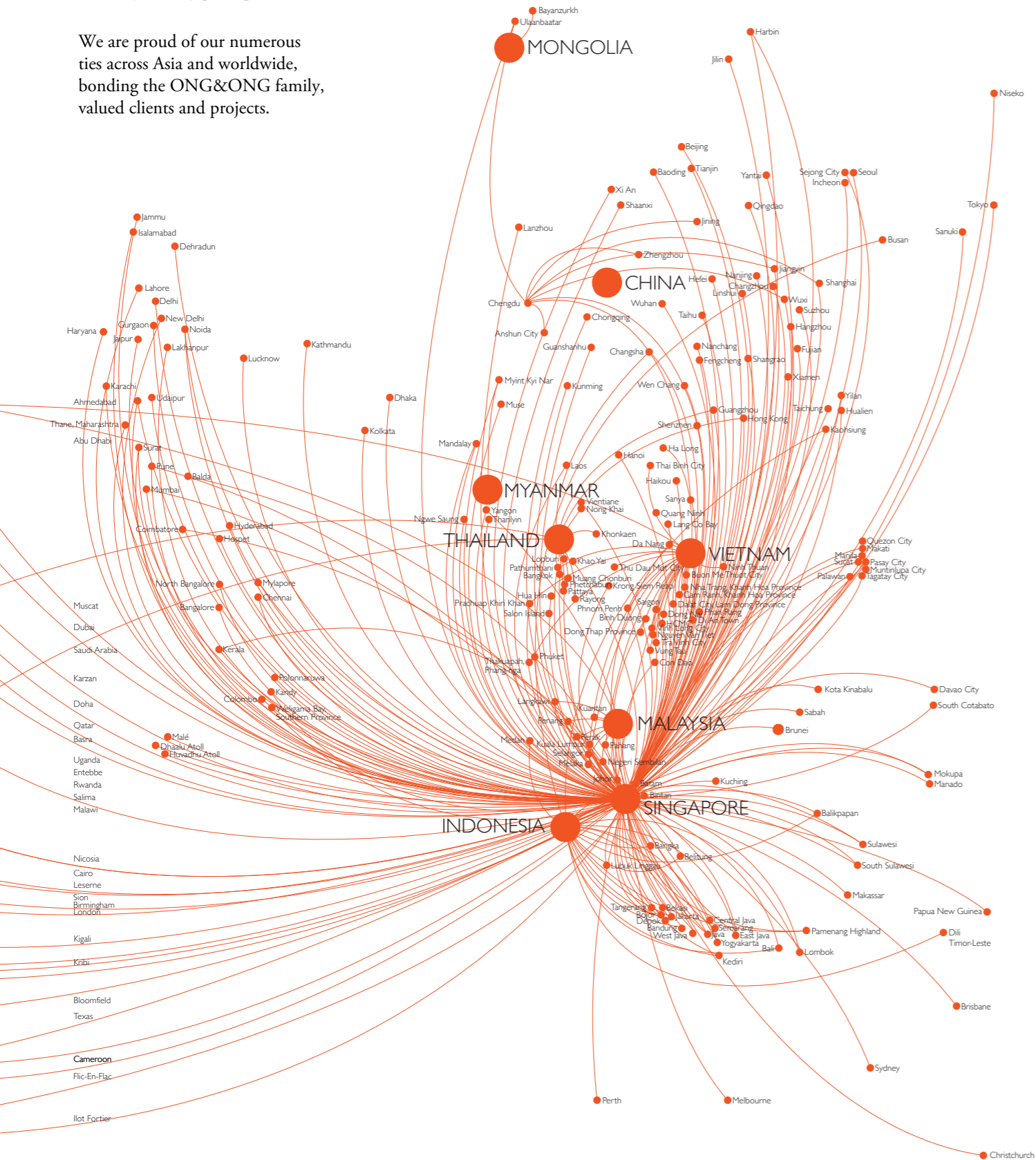

EXPERIENCE
BEYOND.

The world's essential growth.



16°C
 SUNNY
Christchurch
 NEW ZEALAND

UNCOVERING OPPORTUNITIES

未來
Future
எதிர்காலம்
भवा ष्य
Masa Depan
Ирээдүй
အနာဂတ်



CONTENTS

Grandeza



Cliveland House

- 12 Quick Facts 18/19
- 14 Icons: Regional Creations
- 49 BeyondX: Harbingers of Technology
- 50 Future Proofing: The Internet of Things
- 52 Future Forward Tools
- 60 Specialist: Taking a Holistic Approach
- 74 Inspirational Guides: Directors and Team Leaders
- 78 Power to the People: The Command Centre
- 80 Orchestrating a Bespoke Experience
- 82 Financial Review
- 85 Our Organisation
- 86 Global Reach
- 87 Contact



Taipei Fubon Bank



Seoul Club

อนาคต
tương lai
Kinabukasan

EXPERIENCE
BEYOND.

A world of potential.



18°C ☁
PARTLY CLOUDY

Birmingham
UNITED KINGDOM

UNCOVERING OPPORTUNITIES

ONG&ONG QUICK FACTS: FY18/19

WE UNDERSTAND ASIA

THE ONG&ONG GROUP

8

COUNTRIES

- SINGAPORE
- MONGOLIA
- CHINA
- MYANMAR
- INDONESIA
- THAILAND
- MALAYSIA
- VIETNAM

SECURED

300

Projects



LIFELONG LEARNING CULTURE PROGRAMMES

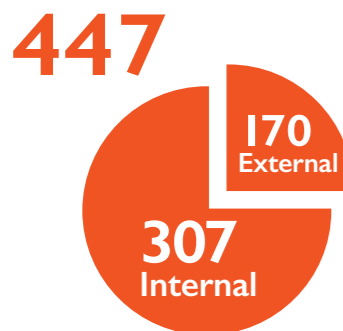

More than 13.2 learning instances per day

Multi-Disciplinary Appeal

POWERED BY

637

Professionals

41

specialising in various disciplines

Multi-disciplinary current projects

REDUCTION
in Sick Leave compared to FY17/18

8%

360Fit rewards

Medical benefits

Health screenings

Capability Development

Continuously improving our expertise in

- DIGITALISATION
- DESIGN
- INNOVATION
- PRODUCTIVITY
- SERVICE EXCELLENCE
- SUSTAINABILITY

87%

Hired locally

>15

Nationalities working together

We are

Glocal

Giving back through education

- Collaboration with educational institutions
- Student office tours
- ONG&ONG travelling fellowship

FUTURE-READY PRACTICE

AGILE WORKSPACES WITH BIM	AUTODESK AUTHORISED TRAINING CENTRE
100% CLOUD OPERATIONS	EMBRACING DISRUPTIVE INNOVATION
BEYONDX	AUGMENTED AREAS
SPEARHEADING ONE OF SINGAPORE'S FIRST IDD PROJECTS	

EXPERIENCE BEYOND.

Where the world's your oyster.



UNCOVERING OPPORTUNITIES

Cross-country collaborations have allowed our offices to take ONG&ONG's design expertise international, enabling us to **change lives for the better.**



INTERIOR

Seoul Club Seoul, South Korea

Principal Leads and Team Members
**Teo Boon Kiat, Amy Ling Tien Keen,
Lester Han Fengguang, Jane Koh Suat Mui
and Mendoza Jacqueline Amparo**
Interior Design

Located along a precipice, Seoul Club is slated for a complete revamp. Foreigners have a strong standing in the club, and this has informed a contemporary design scheme with timeless presence.

It is the club's first makeover since its relocation from Chongkundang Building to Jangchung-dong in 1985, addressing modern needs including updated automation, circulation and improved space allocation.

Previously with two entrances, guests now enter via a single lobby, integrating the user experience. Utilitarian planning needs

for the interiors meant combining spaces for efficient maintenance, such as unifying both the all-day dining bar and western dining areas on the second level. Initially, the bar was set apart due to stringent Korean alcohol laws, that prohibited the bar from being within sight of minors.

This inadvertently caused the space to be massively underutilised during the day, while the dining areas were full due to the surplus of guests. The new flexible design of the bar vicinity allows it to be used for the dining crowd in the day, while continuing to be a bar in the evenings. completion mid-2020.

The bakery kitchen, previously located on the second level, was brought to the ground floor to enable an all-day breakfast experience overlooking the swanky swimming pool. These changes have simplified the main spaces and reduced the man-hours required for tending guests.

Pockets of space that were previously underutilised have been repurposed, while an overhaul is in the works for other existing facilities. Seoul Club's updated interiors are slated for completion mid-2020.





BECA-House Singapore

Principal Leads and Team Members

**Maria Arango, Diego Molina,
Tomas Jaramillo Valencia, Julius Caramat,
Eleazar Cortazar and Ong Ai Li** Architecture



The homeowners' request was simple: they wanted spacious, well-ventilated areas with a green influence that catered to the needs of their paternal grandparents. This resulted in a home with multiple uses of spatial borrowing, defined by high perfect rectilinear lines. From the entrance, the wide porch is angled like a shoebox, connected to the main block with aluminium louvre patterns. The porch accompanies a retained Bucinda Tree and garden plot, with an undulating pebble and granite pathway as a gentle transition from greenery to the interiors.

The Communal Space

A common challenge in Singapore is the proximity of neighbours, which led to the facade sporting distinctive aluminium screens throughout the second and third levels, adding privacy to the interiors. Surrounded by tinted floor-to-ceiling windows that borrow the surrounding greenery, the living room is the main area for all three generations to congregate. The clean space combines the seating area, dining area and dry kitchen, all with pure grey marble flooring. A quartz countertop faces the sitting area, with convenient built-in appliances against wooden laminated cabinetry.

Sisterhood on the Second Level

The cantilevered teak stairs leads to a clean approach by way of wooden wall panels, revealing the daughters' rooms. Connected by a Jack-and-Jill bathroom, it was the owners' intent to maintain interaction between the siblings.

Planter boxers and draping vegetation demarcates the level, softening the exterior façade and elevating the garden feel. A plywood spray-painted veneer wall leads to the family room, with similar traits from the main living room.

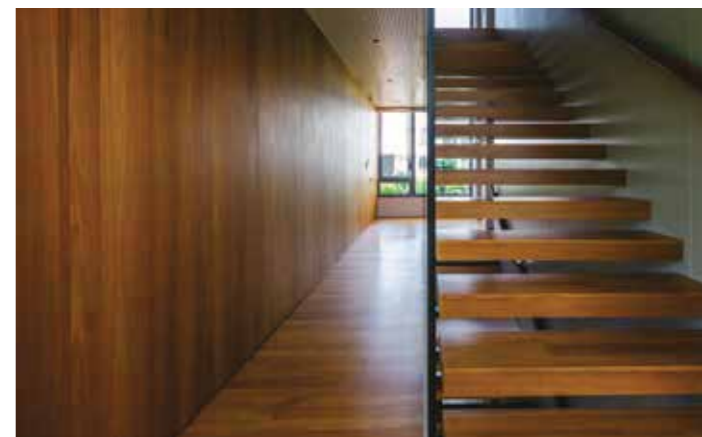

A Master Bedroom to Envy

A similar design language continues on the third level, unveiling the master bedroom and grandparents' room. A shared but divided teak deck provides spatial freeplay for a rattan day bed or even a hammock.

The grandparents' room features antique dark wood furniture almost 50 years old; heirloom pieces that preserve a sense of familiarity for the elderly couple.

In the master, the bed faces the deck, allowing the owners to rise with the sun's morning rays. An entire wall was dedicated to a meticulously designed wardrobe for the couple. The master bathroom is screened by planters and aluminium louvres, giving a resort-like experience of showering amongst nature.

Going green, the home's rooftop solar panels reduce daily energy consumption while the abundance of greenery provides visual comfort and naturally cools the house. The louvres, in turn, redirect incoming sunlight away from the interiors.





Jurong Central Plaza Singapore

Principal Leads and Team Members
Steven Low, Ong Hwee Jin, Tong Pey Haw, Belinda Wong, Greg Cinco and Debbie Sim Architecture
Teh Yong Hui, Brandon Li and Chng Wei Xiang Mechanical & Electrical Engineering
Lim Yan Ping and Slamet Gunawan Civil & Structural Engineering

Replacing the Jurong West Market after a fire razed it in 2016, the new Jurong Central Plaza has been designed as an Active Ageing Hub (AAH), providing day rehabilitation services for seniors.

Part of the revitalisation of Jurong Central Neighbourhood Centre, it consolidates the open spaces with the introduction of a community pavilion, public amenities at strategic nodes and greening of the landscape. The complex features a spacious market and coffee shop on the first floor, with senior services on the second.

Architecture

The complex is built with a louvred pitch roof and columns, taking reference from surrounding blocks for inspiration, and adopts a "canopy of trees" aesthetic.

In this way, Jurong Central Plaza reduces its impact as a new building in a developed neighbourhood, embracing the area's vernacular.

The building mass was stepped down to mitigate obstructing the views of the nearby blocks, while pedestrian walkways connect to the blocks within the vicinity.

The facade panel modules and materials are made of float glass, precast concrete panels with formliners and aluminium louvred casement windows, to encourage natural light usage, while maintaining low heat retention.

Design Improvements

Various improvements were made, with wider aisles in the wet market, improved ventilation through high-volume low-speed (HVLS) fans, a drop-off porch and service bays.

Due to the ageing population, the surrounding blocks enjoy improved connectivity, with added landscaping to soften the urban hardscape.

Elder-Friendly Features

The plaza is designed for the elderly with brightly lit corridors, non-slip tiles, and handicap and ambulant toilets. The lifts are centralised to reduce travelling distance. Access corridors and the wet market were retained in the same locations to assist those with memory deterioration.



Community gathering under the shelter of trees



Re-interpreting community gathering space



Park Origin Phayathai Bangkok, Thailand

Principal Lead
Ong Qi Rong Architecture



Cities are often defined by their communal spaces, with large portions dedicated to green spaces. Inspired by the urban parks of Bangkok, Park Origin was conceptualised to deliver a green third space to its residents.

Tucked away amidst the city's bustle, it serves as a haven, visually enticing passers-by with its greenscape and sense of tranquillity.

Predicated on a park-like experience replete with all of nature's pleasures and wellness benefits, the L-shape plot was ideal for a tower and block hybrid. The massing tapers vertically, with terraces on selected floors, like a giant set of steps. These terraces are linked via stairs, encouraging social interaction between

neighbours, and creating gardens in the sky that boast expansive views poised #FortheGram. Residents thus enjoy the everchanging sights of the surrounding urban scape from the comforts of a lush haven.

Amenities are not in short supply, with a park lawn, children's playground and water features. Fitness is addressed with a lap pool and gym, elevating the mind with views of verdure and rejuvenating the body.

In sum, the green spaces coalesce to form a mini mountain trail, breaking the monotony of Bangkok's high-rises. Park Origin stands out against the city skyline with the prominence of a majestic towering mountain.



**แรงบันดาลใจจากสวน
สาธารณะที่แทรกตัวอู้นเมือง
เราจินตนาการถึงวิถีชีวิตคน
เมือง ที่สัมผัสสวนธรรมชาติ
สุนทรีย์ภาพที่เข้าถึงง่าย
การออกแบบรูปทรงอาคาร
ที่ระเบียงลดหลั่น ผสานกับ
พื้นที่ สวนที่ไต่ระดับไปยัง
ท้องฟ้า เอื้อให้เกิดพื้นที่สวน
ที่ผูกอาศัยเข้าถึงได้เพียงไม่
กี่ก้าวจากประตูบ้าน สะท้อน
รูปแบบการใช้ชีวิตหรูหราและ
ปราณีต**

Gold Coast Sea View Apartment

Jakarta, Indonesia

Principal Leads and Team Members

Kurjanto Slamet, Loh Kah Wai,
Patricia Widjaya and Giovanni Bautista

Architecture

Teo Boon Kiat Interior Design

Lena Quek Landscape



Set amidst a mature mangrove nature reserve waterfront, the architectural language reflects the serene nature of sea breeze. Driven by the concept of an Eco-Isle, or Ecological Isle, the development was conceived as a series of "isles", inspiring its resort-themed residential interiors.

The Residential towers were designed to maximise the sea-view of the site with a "Y"-shape layout, providing spectacular views out to the Java Sea. 32 terracing units line the podium front, located conveniently to multiple pools on the ground floor.

The "C"-shape arrangement of the towers was angled with the intention to make a vast communal space on the ground floor, where one can indulge in the facilities and multi-faceted outdoor environment.

The walk among tree houses, ecological ponds and aromatic species of flora, complete with the mangrove foreground, enable residents to fully embrace nature. On the podium roof, a multi-purpose floating pavilion takes centrepiece of the facility floor.

The fine lines created on the building facade and the full height glass echo a contemporary lifestyle concept, expressing the modernity of the development.



Terciptanya sebuah kawasan pengembangan yang modern dengan pendekatan desain kontemporer, diwujudkan dengan geometri garis dan full height glass pada fasad bangunan.

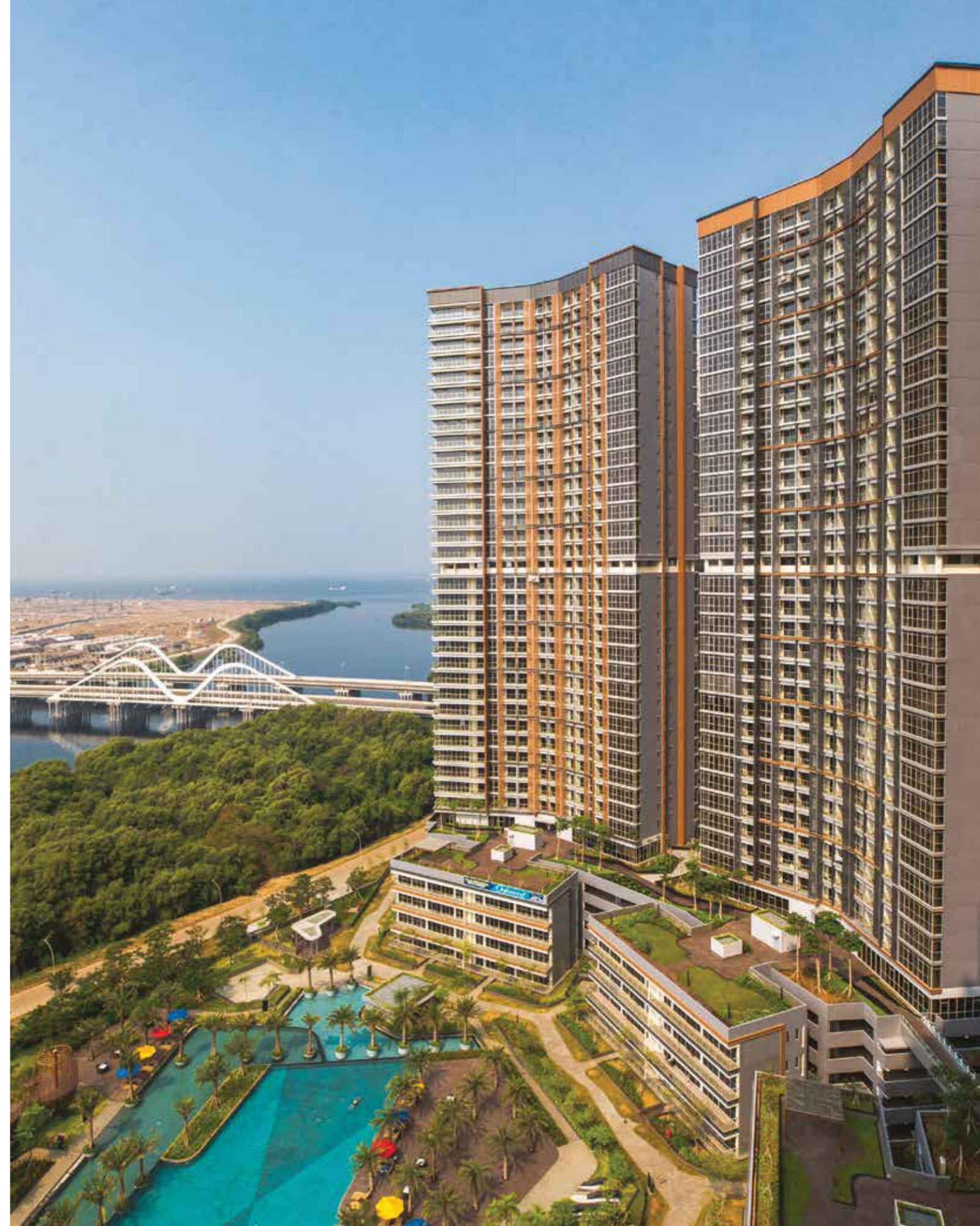

Jakarta MRT

Jakarta's Mass Rapid Transit stations include fine touches of local heritage.

Jakarta, Indonesia

Principal Leads and Team Members
Wendy Tan, Wang Lai Meng,
Anthony Gaza, Elmer Jay Caparros,
Jojo Leonardo Salvador, Allan Censon
and Oliver Imperial Architecture

The new Jakarta MRT Line has 13 stations, spanning a total route length of 13.7km. ONG&ONG helmed two projects comprising four stations in total: Senayan, Istora, Bendungan Hilir and Setiabudi.

All four of the stations are located within the Sudirman Central Business District (SCBD), with their entrances allowing seamless pedestrian flow, and future proofing knockout panels for additional connections based on the master plan.

Indonesian culture is prevalent within the SCBD, and many buildings reflect the art and traditions of the community. This sparked the idea of incorporating historic vignettes in the stations, to emphasise the city's rich heritage.

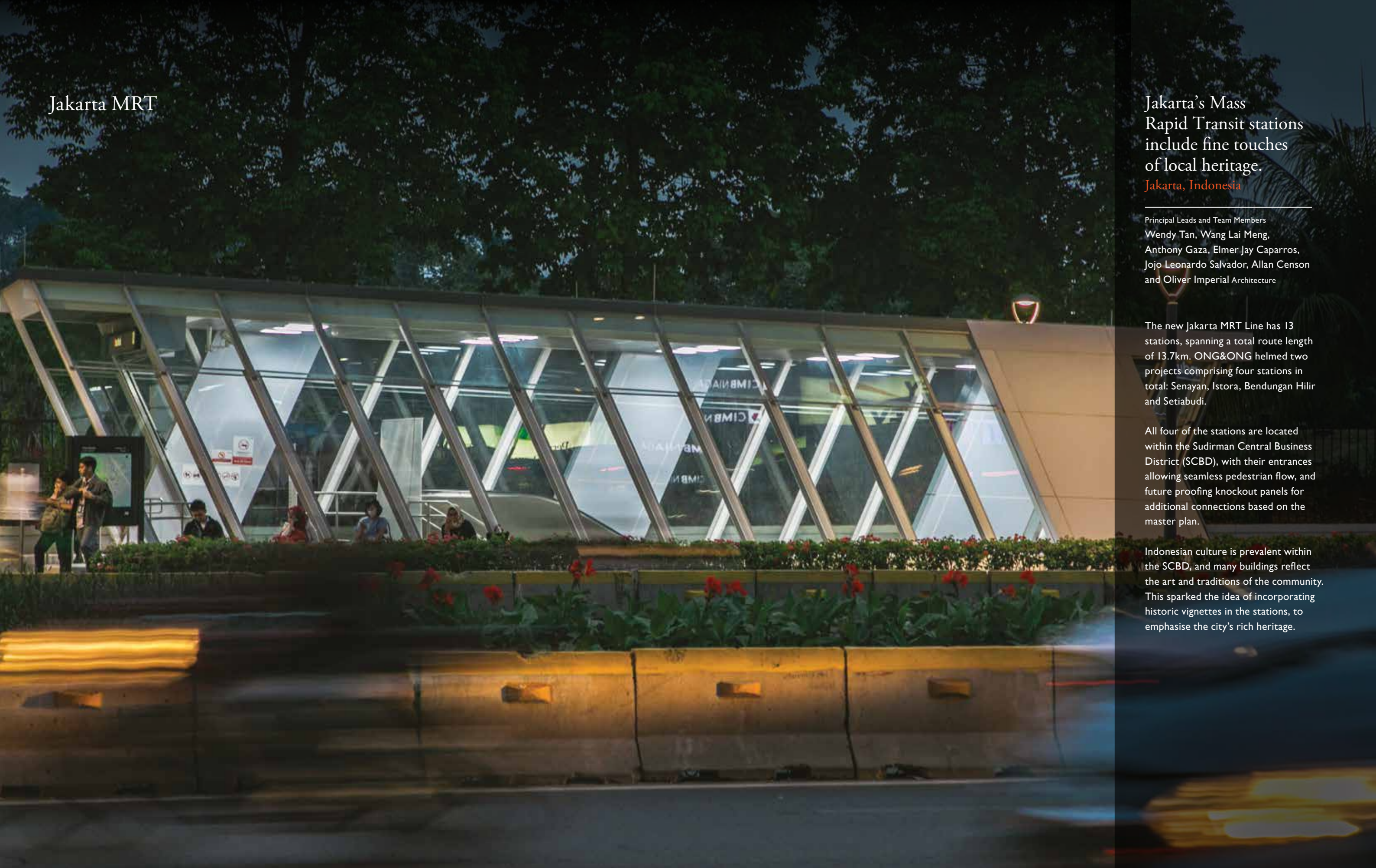

Guiding Motifs

Each of the stations utilises a motif that recalls its inspiration, guiding commuters to the platform from the entrances. Based on a variety of ideas, from the Areca Palm blossom to abstractions of human movement, each concept was thoroughly developed.



Senayan Station Wealthy & Prosperity Motif Kawung pattern

A wealth of history, culture and business is found around this part of the city, represented by overlapping circles that signify the perennial connections between the past and future. Kawung holds much of the rich history of Indonesia, based on the Areca Palm blossom, inspiring its well-balanced four-lobed design.

Bendungan Hilir Branches of Nature Nature Motif

The greenery surrounding this station was translated into a brown linear motif and a secondary pattern mimicking tree branches, communicating a tranquil and bucolic landscape. This results in a calming ambience.



Setiabudi The Freedom Fighter Sacred Motif

The columns of the concourses and floor patterns are inlaid with touches of gold, with a Islamic geometric design symbolising infinite growth, elegance, class and respect. The wayfinding allows users to visually connect with the station and remember it the next time they exit a train.

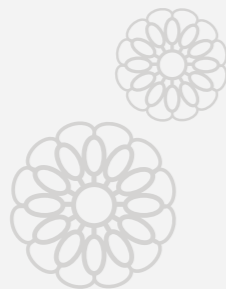

Istora Human Power Wave Active Motif

The modernity of the SCBD continues into the station with this motif, while embracing the spirit of athletes. The motif reflects the active lifestyles of sportsmen and was developed into a "Human Power Wave" concept. Simple modular elements based on the movement of athletic professionals support wayfinding and give a modern feel to the station, resulting in a striking, orange colour accenting the interiors.



Senayan Station



Istora Station



Istora Station



Bendungan Hilir Station



Bendungan Hilir Station



Bendungan Hilir Station



Bendungan Hilir Station

Senayan Station

Located conveniently within the shopping district, Senayan City, Senayan station is located near Summitmas Tower 1, AXA Centre, Ratu Plaza, Kementerian Pendidikan dan Kebudayaan and FX Plaza, easing traffic congestion.



Senayan Station

Tournament, of which Indonesia emerged the proud champions of the coveted Thomas Cup.

The station's locality is near the Sports Centre and SCBD area, including Bapindo Plaza, Bursa Efek Indonesia and Ritz Carlton. With more developments in the pipeline, Istora Station is primed for an upsurge of commuters.

Bendungan Hilir Station

Bendungan Hilir translates as "Downstream of the Dam", and is one of the administrative villages in the Tanah Abang district of Indonesia.

Senayan is shortened from the word Wangsanayan. Wangsanayan was a Balinese Lieutenant who was part of the administrative village in the Kebayoran Baru sub-district. He lived toward the end of the 17th century. Presently, the location harbours commercial ventures and is reputed for its various lifestyle businesses.

Located near to Asuransi Dayun Mitra, Wisma Sudiman, Intiland Tower and Le Meridien Hotel, the station successfully mitigates traffic congestion. The River Kali Krukut is nearby, providing a natural source of design inspiration.

Setiabudi Station

Ernest Francois Eugene Douwes Dekker was an Indonesian freedom fighter and politician in the late 1800s. After Indonesian independence, he adopted a Sundanese name, Danoedirdja Setiaboedi, from which this station derives its moniker. He remains a city hero till today.

Istora Station

Istora's origin comes from Istana Olah Raga, translated as The Sports Palace. It was first used as an indoor multi-purpose sports venue to stage the International Badminton



Setiabudi Station

Grandezza

Selangor, Malaysia

Principal Leads and Team Members

Tan Kee Keat, Maria Arango,
Diego Molina, Jaramillo Valencia Tomas,
Ismed Chayadie Bin Che Din,
Phang Shouk Yan
and Saiful Azri Bin Mohd Husain

Architecture



Nestled within Eco Sanctuary, a major township with abundant facilities, green landscapes, and extensive accommodation types to suit different needs, is Grandezza — a luxurious community of spacious landed homes. Covering 68 acres, the unique settlement is pampered by fully integrated pedestrian walkways, lush green landscapes and a premium club house.

Comprising 100 bungalow and 160 semi-detached units, the low-density enclave supports Eco Sanctuary's commitment to have a generous portion of its land dedicated to greenery. The layout is orderly and reflects meticulous planning.

The gateway entrance is profound and provides a dramatic, majestic greeting to the residences within. The design language continues to the roundabout, with water features and sculpted trees.

The residents access the centralised clubhouse via this point, which exudes a premium ambience with cubist motifs.

Nearly 25,000 sq ft, the clubhouse emulates a luxury resort with elegant cubism-inspired architecture. Boasting a 30-metre swimming pool and Jacuzzi, timber decking and an elevated gym, it is also the first development in Malaysia to offer on-site care and



wellness services, positioning Grandezza as a fully-equipped development.

The orthogonal expression conflates contemporary trends with tropical architecture. Though facing out onto the street, the balconies are treated with composite wood shutters to provide ample privacy. Cross ventilation and smart orientation tackles the tropical climate and over-dependency on air conditioning, while the layout ensures ease of navigation.

The rear of the house offers additional views of the landscape and clubhouse adjacent to the residents. The greenery provides areas for interactions between neighbours making for a potential jogging trail.



Selamat, luas dan canggih, Grandezza merupakan pilihan utama bagi pembeli era moden dari seluruh pasaran Asia.



Sala City

Ho Chi Minh City features a dizzying mix of commerce and culture, where classic Gallic landmarks mingle with towering skyscrapers. This mixed-use commercial and residential township offers a unique assortment of housing options, from luxurious condominiums to extravagant villas. Inspired by the surrounding nature and panoramic views of the river, the ONG&ONG Group provided various services to make this development a true success.



Sarina

Ho Chi Minh City, Vietnam

Principal Leads and Team Members

Hoang Huu Dung Architecture

Raymond Thai Don Thanh Interior Design

Ryan Huynh Ngoc Nghia

Mechanical & Electrical Engineering

Dang Hoang Tung Civil & Structural Engineering

Within the massive Sala City lies Sarina condominium, a three-block residence comprising three floors of retail and seven floors with 233 apartments. The two- and three-bedroom units feature full-height glass windows, capitalising on its linear layout for a better view of the surrounding scenery. While this allows natural light to flood the living space, including the kitchen, the glass balconies further maximise the vantage point.



The fourth floor deck features modern amenities including a club house, gym, lap pool and children's pool; further bolstering the quality of life for residents.

Inspiration for the landscape was drawn from the nearby park, establishing Sarina as an extension of the verdure. This places residents in a natural setting, with all the perks of refined living.



...trong một khung cảnh tự nhiên, với tất cả đặc quyền của cuộc sống tinh tế.

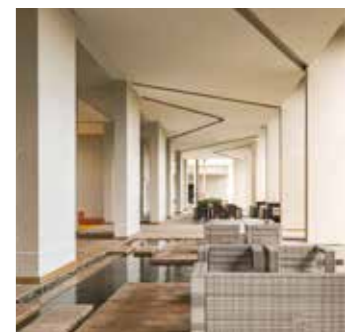

Sadora

Ho Chi Minh City, Vietnam

Principal Lead and Team Member

Hoang Huu Dung Architecture

Raymond Thai Don Thanh Interior Design

The residence is envisaged as an exclusive modern residence, consisting four 22- and 25- storey blocks and three floors of retail. Residents of the 605 units will be able to revel in carefully curated interiors that encourage family cohesion.

Situated above the retail floors is a deck of shared facilities which connects all four

blocks including a swimming pool, an equipped gym, a spa and a playground. Along with a barbecue area, the extensive landscaping provides a relaxing setting for the surrounding blocks overlooking the communal space. Sadora offers convenient urban living, keeping residents close to nature while keeping pace with modern living.



Mang thiên nhiên gần gũi với con người trong nhịp sống hối hả thời hiện đại.



Sarica Ho Chi Minh City, Vietnam

Principal Leads and Team Members

Hoang Huu Dung Architecture

Raymond Thai Don Thanh Interior Design,

Ryan Huynh Ngoc Nghia

Mechanical & Electrical Engineering

Dang Hoang Tung Civil & Structural Engineering

Anna Huynh Thi Quoc Huong

and **Lena Quek** Landscape

Sarica boasts a total of 368 residential units within four 12-storey blocks. The development can be found at a 15,638 square metre site along a river, putting it in the heart of nature. This new residential development promises a luxurious lifestyle. A deck at the 4th floor is available to residents, offering uninterrupted river views and modern amenities like a swimming pool, gym, sky lounge with landscaped greenery.

The layout of project is designed with attention to detail, maximising the number of units, but also ensuring great living space for residents. Each unit comprises bedrooms, living room, kitchen and dining space, bathrooms, and laundry yard arranged logically.

Floor-to-ceiling windows are used to optimise usage of natural daylight and reduce energy consumption while giving a spacious feel. The interiors possess a timeless quality which complements building's architectural features to create warm and tasteful homes that fully embrace the wonders of nature.



**Sáng tạo tổ ấm trang
nhà và ấm áp, hoàn
toàn ôm trọn tất cả sự
kỳ diệu của thiên nhiên.**

Sarimi Ho Chi Minh City, Vietnam

Principal Leads and Team Members

Hoang Huu Dung Architecture

Raymond Thai Don Thanh Interior Design

Ryan Huynh Ngoc Nghia

Mechanical & Electrical Engineering

Dang Hoang Tung Civil & Structural Engineering

Anna Huynh Thi Quoc Huong Landscape



Boasting 368 units within four 8-storey blocks, Sarimi is sited beside a river, from where it draws its nature-inspired concept.

The premium-styled residence offers modern facilities including a pool and gym, a landscaped sky lounge and a deck on the 4th storey touting a sweeping view of the pristine river.

The design intent was to maximise the number of units, while paying keen attention to the details. The floor-to-ceiling windows allows ample daylight to flood all rooms, reducing energy consumption while making the interiors feel more spacious.

The contemporary fittings complement the building's dynamic architectural features to create a warm and pleasant home which embraces the outdoors.



Sofic Ho Chi Minh City, Vietnam

Principal Lead and Team Members

Stanley Tan, Emeric Lau and

Jacqueline Ong Brand Engagement

sofic

In line with the brand naming format beginning with "So" in its name, the second syllable "fic" was derived from the word offices, directly referencing the tower's purpose.

The last letter, "c" in Sofic represents a 360-scan, not unlike a radar or wide helicopter view that modern businesses should adopt. Coupled with silver and grey tones that represent its sophistication and clean aesthetic, Sofic encapsulates modern working spaces and dynamic style.



Residence 60

Ulaanbaatar, Mongolia

Principal Leads and Team Members

Lim Kok Hui,
Galdansambuu Tsolmonbayar
and Ganbat Tamir Architecture
Teo Boon Kiat Interior Design
Stanley Tan and Emeric Lau

Brand Engagement

Их хотын дүр зураг харагдана

A cross-country collaboration with ONG&ONG, Residence 60's architecture was spearheaded by the Malaysia office, interior design by the Singapore office while the Mongolia office executed the project.

Located in Ulaanbaatar's city centre, Residence 60 is a premium dwelling, with 15 storeys comprising 79 units across 1,000sqm in a selection of layouts. The apartments are ideal for young families and urban professionals who prefer a SOHO concept, with modern facilities and indoor garages as extra perks.

One of the capital's finest residential developments, boasting panoramic views of the cityscape, it is a perfect haven for relaxing and recharging.

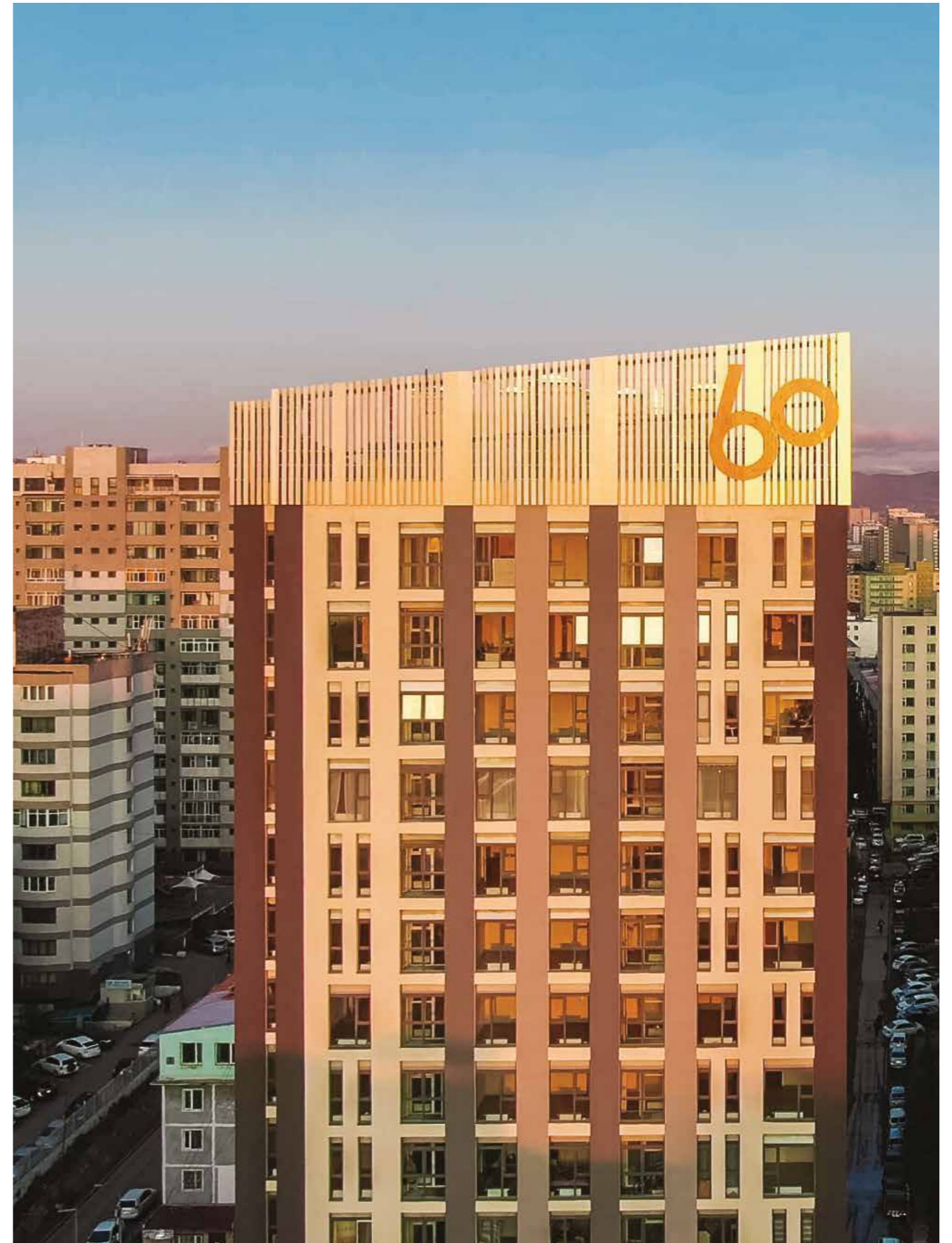

Taipei Fubon Bank



Banking can be a perplexing experience when travelling from place to place, due to the varying areas of focus in each region. With this challenge in mind, Taipei Fubon Bank sought SCA's and ONG&ONG's expertise, and with the combined efforts of the various country offices, conveyed the brand's design language successfully across Vietnam, Indonesia and Singapore.

Taipei Fubon Bank Singapore

Principal Leads and Team Members

Elli Wang, Michael Gong, Wafi Afandi and Muhsin bin Ithnain

Workplace Interiors

The pioneering project that kicked off all the offices' transformations, the Singapore office inspires a sense of progressiveness. The interiors were designed to capture the connections between colleagues,

breaking down barriers to allow the team to tackle challenges cohesively.

The office combines formal and informal meeting areas, creating a hive for creativity amidst the working environment. Engaging breakout areas were introduced at the front of the house, followed by a lounge space that can be repurposed as a learning area.

State-of-the-art technology augments the Treasury Trading room and the rest of the office, creating a modern and flexible workspace.



Taipei Fubon Bank Jakarta, Indonesia

Principal Lead and Team Member

Teo Boon Kiat and Lester Han

Interior Design

Keunikan Asia, Sepenuhnya Fubon.

Set within a prime building in Jakarta, Indonesia, Taipei Fubon Bank premises comprise modern collaborative spaces, with an open workstation and a stylish conference room. The fresh perspective allows for multiple configurations, from talks and sharing events, to in-depth presentation meetings. The design language is a clear homage to Batik, including the glass partitions, wall graphics and upholstery, making the space distinctly Indonesian. Uniquely Asian, and totally Fubon.



Taipei Fubon Bank Ho Chi Minh City, Vietnam

Principal Leads and Team Members

Elli Wang, Michael Gong, Wafi Afandi and Muhsin bin Ithnain Workplace Interiors
Raymond Thai Don Thanh, Bui Thi Bang Tam, Le Anh Triet and Au Nguyen Thuy An Interior Design

The inspiration for this office was predicated on the corporate culture and carving a sense of belonging among colleagues. Cohesion is the aim for this new premises, with plenty of space for social interfacing. The suspended lampshades resemble coolie straw hats, in a reference to local culture.

A welcoming and intriguing breakout area was introduced at the front of the office, followed by a lounge space. With open plan workstations and an updated treasury trading room, the interiors revitalise the office in Ho Chi Minh City, replete with the latest modern installations.



Lấy nền tảng là văn hóa doanh nghiệp để hình thành sự gắn bó giữa đồng nghiệp với nhau

Swiss Garden Hotel Kuala Lumpur, Malaysia

Principal Leads
Paul Roger Lim Project Management
Teo Boon Kiat Interior Design



The challenges for this Additions and Alterations project were demanding relative to other projects, but not insurmountable. They included a full rejuvenation of the Swiss Garden Hotel's rooms, six meeting rooms, a sparkling new swimming pool and a porte-cochère.

And the timeline? A tight four months. The management chose to shut down the hotel while the works were in progress. The upgraded hotel boasts a fresh, contemporary design in the guest rooms with warm, welcoming colours and integrated modern amenities.



INTERIOR DESIGN





ENGINEERING

Sentosa Outpost Village Barracks Hotel

Singapore

Principal Lead and Team Member
Vivian Feng Wei and Jimmy Ang
Mechanical & Electrical Engineering

An integration of three distinctive hotels – Outpost Hotel, Village Hotel and Barracks Hotel at Singapore’s hallmark island resort, Sentosa, the accommodations total 839 exclusive guestrooms and was designed by ARC Studio Architecture & Urbanism.

While the Village Hotel holds 606 guestrooms and offers an experiential stay for families and business travellers alike, the Outpost Hotel with 193 guestrooms caters to more discerning

types, with stylish interpretations of colonial black-and-white design. It has a dedicated rooftop pool and bar to afford travellers a more upscale ambience.

The 40-guestroom Barracks Hotel is housed in a series of conserved colonial buildings, meticulously decorated to reflect sophistication and elegance. This is befitting of the hotel’s storied heritage. The hotel is ideal for mid-scale events, and has both retail and F&B components.



|| |
Cliveland House
| | |
BIRMINGHAM



Cliveland House
Birmingham, United Kingdom

Principal Lead and Team Member
Stanley Tan and Emeric Lau Brand Engagement

A boutique development comprising almost 60 one- and two-bedroom studio-styled units in the U.K., Cliveland House required IMMORTAL's keen sense of brand positioning to articulate its appeal, along with a visual brand identity and marketing brochure.

Birmingham's growth potential is promising despite the ostensibly tumultuous Brexit situation, and this reassurance had to be conveyed through the marketing brochure with facts gleaned from research papers.



PMID
Malaysia

Principal Lead and Team Members
Stanley Tan, Emeric Lau
and Jacqueline Ong Brand Engagement

A Malaysia-based developer of integrated projects, PMID required an identity befitting its top-notch capabilities, and appointed IMMORTAL for its expertise in brand creation.

A new logo, business cards, letterheads, envelopes, and other essential business collaterals were crafted, based on the brief of showcasing PMID's dynamism.

The result was a starburst-inspired icon, representing holistic strength, vibrancy and energy. The gold tone communicates premium positioning, enabling PMID to confidently engage investors, knowing that their brand truly represents their core attributes.



DESIGNING THE FUTURE

beyondX.digital

8-9
JULY
2020

An Architectural, Engineering and Construction event held in Singapore advocates groundbreaking technologies.

BEYOND X

ONG&ONG Group hosted its first open design technology event in Singapore on Thursday, 11 July 2019. Covering an entire level in SLF Building at Thomson Road, the event opened the floor to technology collaborators and design showcases related to the built environment.

Looking towards the future of building, from Artificial Intelligence to 3D-printed structures, BeyondX encouraged attendees to embrace a disruptive mindset, and to be open to positive changes for the industry.

Trinity Methodist Church and Bedok Public Library were among the many projects cited as prime examples of developments that have benefitted from newer technologies.

Speakers included Adriel Sim from URA DCG, Patrick Janssen from NUS and Felix Raspall from SUTD, while AIRLAB showcased an array of future-forward

solutions, addressing 3D technologies, computational design and digital fabrication respectively.

It was the first time ONG&ONG Group organised a design festival of this scale, and the event was a great success, with tech pundits offering to come on board for its next edition on the 8-9 July 2020.

Ong Tze Boon, Chairman of ONG&ONG Group, opened the event with a statement for thought, **"If you're not the one doing the disruption, regardless of your industry, you will be disrupted."**

Express your interest for BeyondX 2020 here!



THE INTERNET OF THINGS

The best way to pave for disruption, is to be ready for the next technological leap.

IoT, or the Internet of Things, is about extending the power of the Internet beyond, onto processes and environments. With the **hyper-connected 5G** future incoming, armed with download speeds of 2.5 GB/S (gigabytes per second), information is collected and sent back to softwares; allowing for businesses and people to be more connected to the world for better efficiency.

In simpler terms, IoT is the next step towards a **smart city** from the development of 5G. **Internet-connected devices** overtook the human population in 2010, and Bloomberg expects 125 billion by 2030. Intriguing as it may sound, it will take a while for the

tech to stabilise, but we should be well prepared to ride the wave.

With big data coming into the fray and connecting decisions based on patterns analysed from a single computing entity, it does seem like Skynet is materialising. Networks of physical objects with sensors and actuators connect to softwares that allow objects to gather and transmit data, to fulfil human tasks.

Think coffee places that remember your favourite orders, cars that guide you to your usual spot, or for a more morbid example, a major drop in your pulse prompting an ambulance to rush to you.

Internet-Connected Cars

Getting in, your **autonomous car** reminds you of your appointments for the day. It takes the fastest route and adjusts the temperature, seat height, mirrors and even music to your "meeting playlist" instead of your husband's. It pre-orders your latte to-go from your favourite coffeeshop, and reminds you that your stilettos are in the backseat.



Smart Home

Still think of **Google Home** or HomePod as toys for boys? Getting home, the TV switches to your current episode of Black Mirror (5G's peak speed downloads the whole season in 8 seconds). The lights are dimmed, the A/C is turned on. Your roast chicken is reheated. The shower pressure is to your liking, and the garden was watered earlier that afternoon. This is the potential of 5G and the IoT, but with leapfrogging advancement there will be repercussions.



Wearable Devices

You may be wearing one right now. It reminds you to take your daily medication. It then schedules your next appointment for the pain in your left knee. Your cardio has not been fulfilled for the week, and would you like a session with your yoga instructor over the weekend?



A 2017 report from McKinsey Global Institute shares that automation could eliminate as many as 73 million jobs in the USA by 2030. However, a higher demand for server maintenance teams and coders might alleviate a labour crisis.

Additionally, the positive aspects of the IoT, from elevating living standards globally to tackling climate change, far outweigh the negatives.

Possibly the de facto for wireless standards in the future, brands like KMC and Intel are already on its way. Improving BAS (Building Automation Systems), their platform allows for real-time analysis of building information, such as HVAC (heating, ventilation and air-conditioning), and other information that a Facilities Manager can access via cloud. Future developments may enable broader information sharing, allowing platforms to take several actions when a value goes out of the pre-set range. And the applications continue with lighting, fire & safety, access & security, and elevator & escalator management. Modern buildings have catered space for this, and can be modelled to encourage even more technological advances.

The world around us is changing. We must be prepared for full-scale IoT implementation. This may prove to be challenging, as humans are (by majority) creatures of habit.

Cutting to the chase, a series of architectural innovation possibilities are already underway, and set to skyrocket once 5G and the IoT takes flight.

FUTURE FORWARD TOOLS

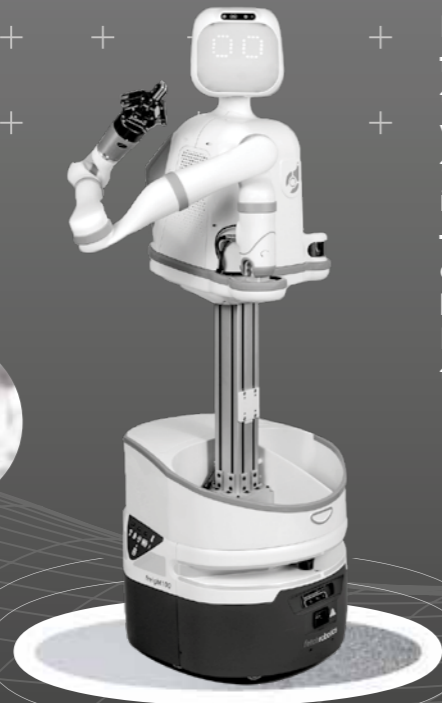
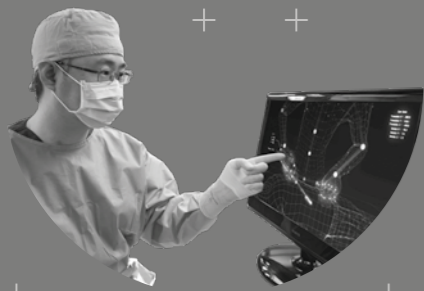

In 2015, the United Nations created 17 Sustainable Development Goals (SDGs for short) for the world to achieve by 2030. As we near the midpoint of this timeline, a raft of innovations are overdue – tools that bring about change and for the betterment of the world. Here are a few that relate to the built environment.



Goal 3 Good Health and Well-Being

1. Redefined care delivery

Centralised digital centres enable decision-making, with continuous clinical monitoring, targeted treatments (e.g. 3D printing for surgeries), and the use of smaller, portable devices will help characterise acute-care hospitals.

2. Digital patient experience

Digital and artificial intelligence (AI) technologies can help enable on-demand interaction and seamless processes to improve patient experience.

3 Enhanced talent development

Robotic process automation (RPA) and AI can allow caregivers to spend more time providing care and less time documenting it.

4. Operational efficiencies through technology

Digital supply chains, automation, robotics, and next-generation interoperability can drive operations management and back-office efficiencies.

5. Healing and well-being designs

The well-being of patients and staff members with an emphasis on the importance of environment and experience in healing is important for future hospital designs.



Goal 7 Affordable and Clean Energy

The Rise of Solar

According to the Renewables Global Status Report, solar is the booming market for four years running; the electricity sector is an unstoppable change, and solar photovoltaics seem to be leading the sea change – 55% of new renewable energy capacity installed in 2018 (according to Ren21).

But that is overselling. Two thirds of the energy in the economy ends up wasted. Fossil fuels are inefficient – there is considerable wastage at each stage of production: mining, transportation, refining and burning. Besides, renewable electricity is simpler, and requires lower maintenance costs.

But the benefits clearly outweigh the current trends: the earth solar energy more than 10,000 than what humanity requires. According to Bloomberg, the lowest-cost energy option in ten years will be solar.

Sunflare now has bendable, super-lightweight solar panels. We might see more of this being implemented on roofs and other outdoor surfaces.

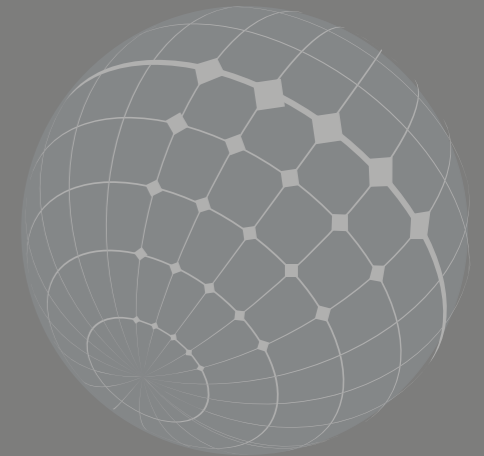

Solving the storage problem for solar, Tesla introduced the Powerwall in 2015, which can hold ten Kilowatt hours (kWh) compared to a car battery's capacity of 1.2kWh. It is a step towards the world adopting clean energy.

Tesla definitely hasn't stopped there. Elon Musk's unveiling of his solar roof tiles has gotten the world keen on adopting solar power, although according to CNBC's release Dan Kammen, Professor of Energy in UC Berkeley, a major change is possible only if **Tesla is able to get the market they are hoping for**, which may take a few more years.

Solar seems **to lighten things up** in recent years, and we can only hope the trend stays.





Goal 11 Sustainable Cities and Communities

Drones are already here. They are extremely agile and precise, and with how affordable and widely accepted they are, architects and masterplanners may viably design drone-friendly cities, assuming that their popularity continues to grow.

Amazon's unveiling of drone delivery has unlocked more potential. Think site analysis by realtors and architects to stitch together photos for 3D maps, monitoring construction site progress and producing dramatic photography of completed projects.

This will completely change the idea of masterplanning, and possibly implement drone-specific lanes, aerial traffic control and drop-off locations.



Drones, as disruptive as the Internet

— Liam Young, Speculative Architect



Goal 12 Responsible Consumption and Production

While this goal is more relevant to the wastage of food, water and raw materials, **the production side of things do matter.**

The factory of the future, is where IT and Operational Technologies converge, and the evolution has many names: Smart Manufacturing, Industry 4.0 or the Digital Enterprise. SCM World supports this, with the Internet of things taking the world by storm.

FACTORY OF THE FUTURE

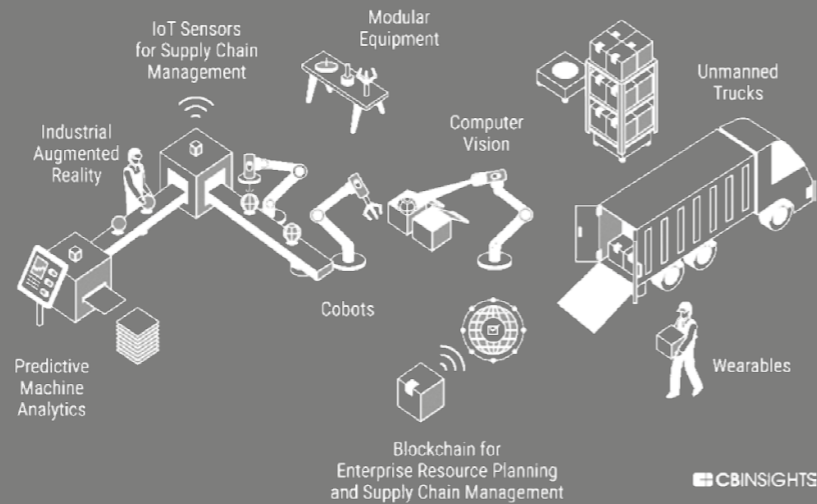

Huffington Post has published documented results, with **82% increased efficiency, fewer defects and satisfaction gains by early adopters.**

Leaving behind dangerous, labour-intensive worksites, imagine fully mobile capabilities, improved computer-assisted design (CAD) systems, late-stage assembly, robotics; predictive analytics, cloud computing and last but not limited to, 3D printing.



Goal 13 Climate Action

Crazy technology is ongoing to combat climate action. Some may take decades to be figured out, while others might not even see fruition.

Next-generation nuclear Terrestrial Energy, in Canada, is developing a design that uses molten salt to produce one-fifth of old nuclear technology. Countries are collaborating in Southern France to use fusion power to create a miniature "Sun on Earth" and to harness its power (Sounds familiar, Dr. Octavius?), and let's not get started with Carbon capture and sequestration — removing carbon from

the atmosphere and storing it underground.

Unfortunately, there are no signs of these technologies accelerating its slow progress, and we must face reality.

The ugly truth: to be naïve as to think technology as the magic wand to every problem stated by the SDG, is a fool wishing for pie in the sky.

The solution might lie in ethical reasoning, as opposed to jejune perspectives. As the gap between current comfort and the tipping point for climate catastrophe continues to close, we might have to ask

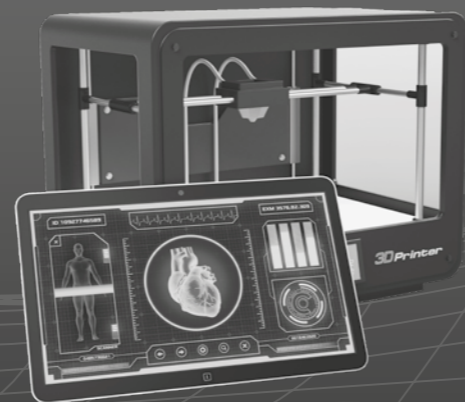

ourselves if we should invest in more drastic solutions that require more research, rather than to hope mankind will abandon its devil-may-care attitude and start realising individual responsibility (Sorry, Greta). It will be a tough decision to make, but when push comes to shove, it may drive us to do the unthinkable, for human survival.

Conclusion

Ultimately, it is about the mindset of every individual. We should adopt an open mind to problem-solving and unconventional thinking to derive the most effective solutions. Being encumbered by convention and backward methodologies will prove the downfall of many, as erstwhile bellwethers are coerced to relinquish their positions.

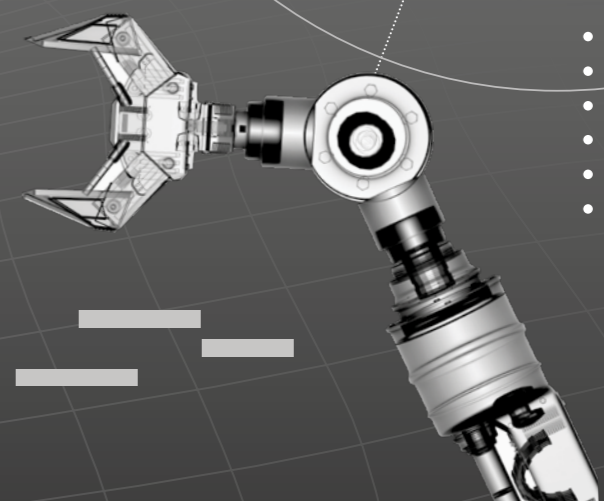
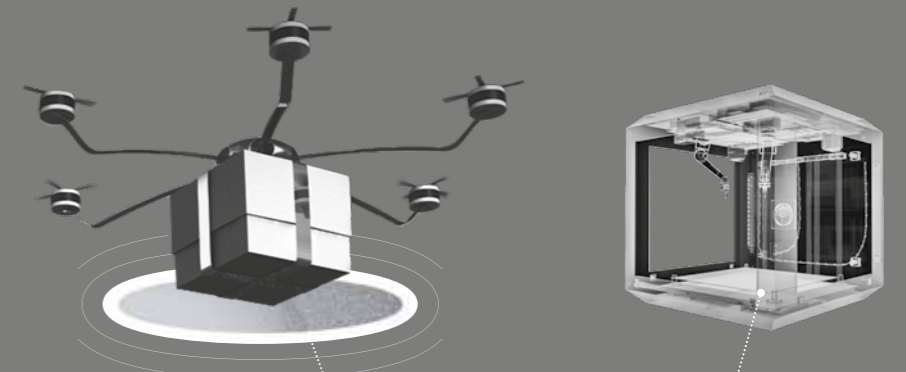

Image Credits
 Elon Musk: www.businessinsider.sg
 Moxi Robot: www.diligentrobots.com
 Vistabule Trailer: www.treehugger.com
 Doctor & Monitor: www.businesswire.com
 Greta Thunberg: Twitter - @gretathunberg

BBR by Alain Ducasse
Singapore

Experience Beyond Gastronomy

Managed and built by Project X:ion
Designed by Jouin Manku

WAY FINDING STRATEGY

The staple for every development,
to ensure all who wander are not lost.

When was the last time you went
about a place, looking for an elevator or
escalator, or the way to the nearest loo?
That wish in your head — “How do you
get to where you want to go?” — is what
Wayfinding is in essence.

Yet that is just scratching the surface.
Wayfinding is a blend of factors that
culminates in an experience beyond
that is both seamless and intuitive.
A precise planning to move human
traffic, it is an intangible design that
the user senses, to get them to places
where they need to be.

IMMORTAL
Brand Engagement

Keeping users connected to nature introduces a multitude of benefits for both space and user, while enhancing the aesthetics with brave overtones.

Heartbeat@Bedok
Singapore

Experience Beyond Biophilia

An ONG&ONG Project

Workplace Interiors

The perfect corporate interior goes beyond simply creating functional workspaces. Although aesthetic quality and style are a must, the environment must be synergistic and inspirational. After all, productivity is the name of the game.

At SCA Design, we go beyond traditional interior design, altering the notion of what a working environment should encompass. Combining in-depth building and workplace studies we determine the ideal parameters for project management. In addition, with input from clientele and the end-user, space planning is used in tandem with flawless interior design, resulting in turn key work spaces that exemplify what the modern office should be.

Building Studies

Workplace Studies

Space Planning

Interior Design

Project Management

Sustainability

Turn Key Solutions



FTI Consulting
Singapore **Office**

Reflecting Singapore's world-class port heritage and efficiency, the office was given a complete revamp to improve collaborations in a modern concept.



ONG&ONG Singapore
Singapore **Office**

Pushing for open workspace collaborations, ONG&ONG was treated to a lifestyle concept across the three connected levels, designing Bar9's bar concept, IODem's play area and District11's hotel lobby.



Knight Frank Office
Singapore **Office**

Embodying the values of the consultancy, the premise is professionalism personified – bright, comfortable and warm, with a modern approach to spur productivity.



Manulife Office
Singapore **Office**

Encouraging employees to be "living the brand", the interiors provide a wide range of options for workstyles, while ensuring functionality, durability and aesthetics are kept on an all-time high.



Digital Content Studios
Singapore **Office**

Singapore's first dedicated facility for digital content creators and game developers, this project aims to nurture a new generation of storytellers.



ONG&ONG Vietnam
Ho Chi Minh City, Vietnam **Office**

The new premises provide ample space for the ever-growing office to thrive in modern capabilities and build on existing camaraderie.



Marina One Lobby
Singapore **Office**

A space for social interaction and luxurious comfort called for SCA Design's touch, creating a cohesive environment.

Engineering

Beneath the veneers of colours, curved lines and textures of all dazzling designs are the hidden machinery and mechanisms that make everything possible. Inventive engineering becomes the basis through which creativity can be transformed from imagination and turned into living, breathing reality.

With decades of experience in the industry, Rankine&Hill consultants have collaborated on some of Singapore's most iconic designs. From Mechanical & Electrical (M&E) to Civil & Structural (C&S), as well as Fire Safety and Environmental solutions, we continue to deliver a full-range of comprehensive engineering solutions that are not only functionally sound, but safe and green.

Mechanical

Electrical

Civil

Structural

Fire Safety

Environmental



Wisma Geylang Serai
Singapore **Institutional**

Singapore's first-ever cultural heritage integrated hub required comprehensive MEP services, integrating with the project's architecture and landscape designs.



Lake Grande
Singapore **Residential**

Melding nature, technology and well-focussed facilities required precise Mechanical & Electrical (M&E) engineering in crafting ideal resort homes.



Apple Jewel Changi Airport
Singapore **Commercial**

The second major store of the household name required concealed C&S engineering, while bolstering its structural considerations and its geometrical necessities.



Pasir Panjang Wholesale Centre Cold Room Facilities
Singapore **Commercial**

As Singapore's main distribution point for a wide variety of consumables, M&E Engineering assistance ensured a clean and modern environment for the 15-hectare supply chain node.



Royal Square
Singapore **Mixed-use**

The M&E engineering for this contemporary mixed development is impressive, featuring both passive and active environmental technology. There are medical suites, retail and a Courtyard by Marriott.



Kallang Riverside
Singapore **Residential**

The residential development of 30-storeys required specific C&S engineering demands which was executed seamlessly.

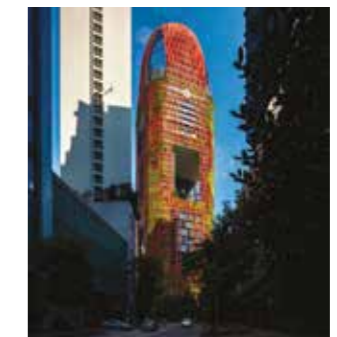

Oasia Hotel Downtown
Singapore **Hospitality**

An award-winning WOHA design, optimally enhanced by an intricate array of M&E systems, complete with heightened safety and sustainability features.



Watercove
Singapore **Residential**

The 80-unit housing development necessitated M&E engineering, with optimal Window to Wall Ratio for improved ventilation and reduction of heat gain.



Novena Church
Singapore **Religious**

Revitalisation of the idyllic church was fastidious work for M&E, with full air-conditioning and installing present-day safety requirements, all while maintaining the integrity of the original site.



The Ascent
Ho Chi Minh City, Vietnam **Residential**

C&S engineering was provided for the 280 apartments and the impressive facilities, offering Singapore-standard urban living in Saigon.



The Waterfront Saigon
Ho Chi Minh City, Vietnam **Residential**

Spanning a gross floor area of 41,000sqm, the office and service apartment development utilised C&S engineering.



Tai Seng Centre
Singapore **Industrial**

The Commercial property of 12 storeys demanded M&E Engineering to accommodate multi-user, light industrial operations.

Project Management

Ensuring projects are well-organised and cohesively executed are the fundamentals of our business. But it is more than just putting the right people in touch or assembling the ideal team. Our goal is to connect the dots and tie up the loose ends to make sure projects are as easy and cost-effective as possible.

The process is a practical one, where first the objectives and parameters of a given project are properly ascertained. Following which, development is carefully planned and mapped, all in an effort to ensure complete alignment and efficiency throughout the construction phase. Because for us, success means a stress-free experience for our clients.

Project Management

Project Development

Construction Management

Cost Management

Place Management



www.proj-innovations.com



DFS Liquor & Tobacco Concession, Changi Airport
Singapore **Retail**

Part of the bid-winning group, we provided project management and cost management services for the newly updated DFS Stores.



DFS Scottswalk
Singapore **Retail**

Provided Project Management and Cost Management services to the client in the refurbishment of the Scottswalk Store.



Singapore General Hospital Emergency Medicine Building
Singapore **Institutional**

Boasting four times the space of its predecessor, the 12-storey emergency medicine building will include rooms to handle disease outbreaks and mass casualty incidents, while improving response efficiency.



Northland Primary School



Swiss Garden Hotel
Kuala Lumpur, Malaysia **Hospitality**

Project management was provided for the remodelling of the 320 guestrooms and lobby, sporting a new warm green colour palette.



Canberra Primary School



Compassvale Primary School



Edgefield Primary School



MacPherson Primary School



Northspring Primary School



Qihua Primary School



Rivervale Primary School



Sembawang Primary School



Anderson Primary School



Bedok Green Primary School

Upgrading of Existing Schools under Peri Package
Singapore **Institutional**

The targeted enhancement of educational facilities island-wide has necessitated coordinated project management to oversee the improvement of numerous schools.

Project Solutions

Let's face it, construction is a messy business. To have each component gel like clockwork requires one source to handle every aspect of a project meticulously.

Moving in tandem with the cultures and processes of countries in and around Asia, keeps us always ahead of the competition with technology advancements and synergistically achieving results. That is true integration.

Construction

Design & Build

Turn Key Solutions

Contract Works



Alodd
Singapore **Retail**



A turnkey solution for the client, this project comprised the creation and delivery of a pop-up store in Centrepoint Mall.



Howards Storage World
Singapore **Retail**

Appointed to carry out rebranding and an aesthetic revamp, the client enjoyed a fuss-free experience with our one-stop shop solution.

Classic British Luxury Brand
Worldwide **Retail**

A classic British Luxury Brand engaged quantity surveying and cost management services for flagship stores in Korea and Japan.

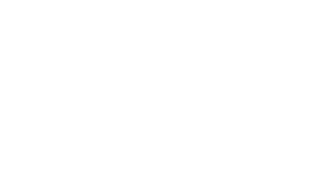

BBR by Alain Ducasse
Singapore **Food & Beverage**

The Michelin star restaurant by Chef Alain Ducasse required project management for the picturesque environment in Raffles' Hotel.

www.proj-xion.com



Intercontinental Jakarta
Jakarta, Indonesia **Hospitality**

Tasked to provide local design implementation, project management and construction management for the global hotel chain's Jakarta property.



Bali International Airport
Bali, Indonesia **Retail**

Provided holistic service to the client, including local design implementation, cost, construction and project management - delivering 22 luxury retail outlets.



Lendlease Marketing Suite
Singapore **Commercial**

Provided a complete turnkey solution for the client's Paya Lebar Quarters project, located in Paya Lebar Square.



BBR by Alain Ducasse
Singapore **Food & Beverage**

The Michelin star restaurant by Chef Alain Ducasse required project management for the picturesque environment in Raffles' Hotel.

Brand Engagement

Brand Engagement is an analytical process, but also one that requires much imagination. It is about crafting experiences that foster relationships between brands and consumers. With almost 30 years of experience and a client list brimming with household names, IMMORTAL is renowned for its branding programmes that have helped many clients grow their businesses.

Offering a comprehensive suite of services including Market Insight, Brand Audits, Strategy, Expression, and Management, IMMORTAL is committed to helping any brand create an authentic and enduring identity.

Market Insight

Brand Audit

Brand Strategy

Brand Expression

Brand Management

Environmental Branding

IMMORTAL

Brand Engagement



New Tech Park
Singapore **Mixed-Use**

Owned by Sabana REIT, this 1980s development at Lorong Chuan was revamped with a fresh facade and new neighbourhood retail mall. The new logo has a friendlier feel, while the plus visual icon reflects the value the mall brings to the nearby community.



Montigo Resorts
Batam, Indonesia **Hospitality**

The brand identity was inspired by a Three Stepping Stones visual hallmark that emphasises both proximity to Singapore, as well as its ability to accommodate multi generational families.



Crystal Galleria
Shanghai, China **Retail**

The kaleidoscopic brandmark embodies the multifaceted attractions housed within this trendy mall, while also reflecting the vibrancy of the Jing'an district.



Parkway Health
Singapore **Institutional**

Reflecting two decades of excellence in healthcare services, the brand architecture for this project unified the company's various entities.



Sofic
Ho Chi Minh City, Vietnam **Corporate**

Deriving from the term "office", it encapsulates the concept of modern working spaces.



Republic Engineers
Maldives **Corporate**

A visual identity was developed based on Singapore's National Identity. The new brand is ready to take on projects at a governmental level.



The Collection
Bangkok, Thailand **Mixed-use**

Predicating the interiors and branding on four fictional characters, the Traveller, the Thinker, the Trendsetter and the Collector – personas that resonate well with the affluent modernist.



OROMA
Africa **Corporate**

Meaning orange in Swahili, the brand was positioned with the tagline "Advancing Frontiers", reflecting the firm's beliefs.



Cliveland House
Birmingham, United Kingdom **Residential**

A compact residential development in Birmingham, the owners needed to position Cliveland House as an attractive investment opportunity to international buyers. The timeless and elegant visual identity created is inspired by the building's brickwork and architecture.



PMID
Malaysia **Corporate**

An outstanding identity that underscores top-notch capabilities of a developer.



Treeline Hotel
Siem Reap, Cambodia **Hospitality**

Envisioned as the new standard for boutique-stay hospitality, the branding juxtaposes Cambodia's Angkor heritage with tasteful modern touches.



Toomato
Bangkok, Thailand **Food & Beverage**

Conceptualised as a humble Italian kitchen, this fast-casual diner prioritises wholesome authenticity to go along with great food and drinks.

Environmental Wayfinding

Effective wayfinding means delivering assurance at every point of a journey. It is a system of signs and symbols to enable easy navigation. No matter the complexity, IMMORTAL's primary objective is to make every space more user friendly.

It has the capacity to guide traffic to a certain area, enhance the built environment, improving circulation, connectivity and use of space.



A vehicular traffic plan depicting traffic flow and routes, and car park ingress and egress points for wayfinding purposes.

Planning and Analysis

Wayfinding Strategy

Signage System and Design

Environmental Graphics

IMMORTAL

Brand Engagement

www.immortal.com.sg



Radia
Kuala Lumpur, Malaysia **Mixed-use**

Visual graphics and colour-coded signage take after the development's curved radial form, with concealed lighting subtly highlighting the wayfinding system.



China Place
Singapore **Mixed-use**

An environmental graphics system that depicts the area's heritage was developed, consisting of building markers, directional and circulation signs.



Guoco Tower
Singapore **Mixed-use**

Revitalising the wayfinding system and re-branding of the building, the clean designs provide overtones of professional charisma.



JW Marriott Singapore South Beach
Singapore **Hospitality**

Reopened under new management, the new signage and wayfinding system reflects the revamped interior's sophisticated tones and sleek, muted look.



South Beach
Singapore **Mixed-use**

Augmenting the end-user experience is an environmental wayfinding system with an impressive digital directory that guides visitors throughout the property.



Trans Studio Mall
Bandung, Indonesia **Retail**

Taking the butterfly as a welcoming visual motif, the development's wayfinding system works to create an open, inviting feel.



Manulife
Singapore **Office**

To ensure circulation was unambiguous, wayfinding signages were provided for the modern office, improving the user experience.



The Park Hyderabad
Hyderabad, India **Hospitality**

Drawing from the iconic building façade, the wayfinding system enhances the visual resonance of the stay experience.



Southern Marina
Johor, Malaysia **Mixed-use**

Astronavigation and unique Origami forms inspired the wayfinding design for this mixed development.

Experience Design

Experience design is about evolving the manner in which we interact with the world around us. It is about altering human experiences through the process of design thinking, where we imagine and conceive in terms of utility to better serve our needs. Human experiences are in constant flux, where improvement, progress and advancement unfold and develop over time – ultimately leaving us better positioned today than we were before.

At ONG&ONG, we believe in design thinking and the impact that it brings. And for our award-winning Experience Design team, the goal is to find ways to elevate and improve an experience or a process. Whether it's a minor tweak or something completely reimagined, all the projects we work on have one thing in common: making the end-user experience better.

User Experience Strategy Service

Design Consulting

Design Thinking

Ethnographic Research



FRANK by OCBC

Singapore **Commercial**

Targeting millennials, we worked with OCBC to re-imagine what a relevant financial service online and offline, would look like for Gen-Ys. When launched, FRANK was called "Maybe the coolest bank Gen-Y has ever seen" by The Financial Brand.



Changi Cove

Singapore **Hospitality**

The management of Changi Cove wanted to build a place of retreat that would appeal to guests who wanted a short getaway to relax, refresh and be inspired again. We worked with them to uncover the different ways guests wanted to 'retreat' and co-created a holistic experience which drew one into the process of rest, reflection, inspiration and creation. Today, Changi Cove is a favourite destination for many personal as well as corporate retreats.



HDB Home Purchasing & SERS Experience

Singapore **Civic**

This was a one-of-a-kind opportunity to re-think the user experience of purchasing a flat, evolving the online, physical and process touch points to redefine a public service offering.



SaladStop!

Singapore **Food & Beverage**

We helped SaladStop! to go deep and discover what their business was truly about. The result is an authentic offering centred around "Eating Wide Awake", a movement for healthy and responsible eating.



Gardens Shop at Botanic Gardens

Singapore **Retail**

Re-imagining how to convey the powerful narrative behind the 158-year-old Botanic Gardens, we worked with Gardens Shop to create a retail concept that would encapsulate the history of Singapore's first UNESCO Heritage site.



SilverKris Lounge

Worldwide **Commercial**

SIA, Singapore's premier airline is well known to promise its customers "A great way to fly". We worked with them to translate this promise into their lounge experience, re-thinking what comfort, luxury and personalised service meant to their premium passengers.

Landscape

The modern built environment is increasingly characterised by the integration of nature. Regardless of typology and scale, projects today make it a point to include greenery where possible.

At ONG&ONG, our track record of award-winning projects underscores the importance we place on landscape design. From biophilic environments and naturalistic designs, to the creation of sustainable microclimates, our landscape team endeavours to find the optimum levels of greenery to benefit and enhance the built environment.

Masterplanning

Space Planning

Blue & Green Solutions

Sustainability

Playground Design



Heartbeak@Bedok

Singapore **Mixed-use**

Originally a public park, this groundbreaking community building features intricate landscape design encompassing an abundance of indoor and outdoor green spaces.



The Creek @ Bukit

Singapore **Residential**

A redevelopment of the former Green Lodge, the landscaping scheme has enlivened the development's perimeter and interiors, extending the sense of greenery from the nearby Bukit Timah Nature Reserve.



River Isles

Singapore **Residential**

Lush verdure surrounds the nine blocks, bringing island life to residents and tranquility among the facilities.



Bartley Ridge

Singapore **Residential**

The project is ensconced within a lush botanic garden, drawing inspiration from nature to create a landscape teeming with life.



8 St Thomas

Singapore **Residential**

Artistic flavours are abundant in this uber-condominium, gathering inspiration from both the nearby water body and greenery, which required our landscape team's expertise.



The Krista

Ho Chi Minh City, Vietnam **Residential**

Conceived to be the perfect living environment for young dynamic families, the setting encourages the pursuit of healthy lifestyles.



Commonwealth Lane: Death and the Community

Singapore **Institutional**

The new columbarium greatly adapted from traditional Hakka architecture, blending traditional building materials and colours while maintaining similar symmetry and oval layout.



West Rock @ Bukit Batok and Park

Singapore **Residential**

A unique landscaped central spine connects the adjacent park with multi-generational amenities, re-establishing the link between nature and living.



Opal Riverside Park

Ho Chi Minh City, Vietnam, **Civic**

Inspired by water, the landscaping for this project evokes coursing movement and vitality.



Frasers Tower

Singapore **Commercial**

Featuring a retail podium beneath the office tower, greenery was extensive throughout the development, including a verdure-rich rooftop poised for events.



Yishun Nature Park

Singapore **Institutional**

Envisioned as a community focal point, the park prioritises eco-friendly practices, containing an impressive variety of local flora.



Farrer Square

Singapore **Mixed-use**

Greenery extends vertically from the lush planting perimeter strip, with extensive landscaping catered for the sky terrace and facilities.

Lighting

Lighting design is crucial, yet too often overlooked. Lighting can highlight and accentuate any space. It can alter the ambience or mood of a given setting, bringing life, warmth and mirth to any environment. Lighting has the capacity to transform a solid project into a superb one, where just the right mix of shadow, light and colour can easily augment the end-user experience.

Bright or low-key, fluorescent or neon, simple or intricate, we at ONG&ONG fully appreciate how crucial a project's lighting design can be.

Architectural Lighting

Equipment Cost Control

Operational Cost Control

Lux Level Calculations

Lighting Controls

Lighting Audits



Trinity Christian Centre
Singapore **Religious**

With the use of dynamic colour changing flood lights, the lighting enhancement greatly impacts the building and surroundings by creating a vibrant and lively atmosphere.



CT Hub
Singapore **Industrial**

Innovative lighting design added character to the industrial building.



Heartbeat@Bedok
Singapore **Civic**

Lighting design complemented the architectural form, continuous greenery and warm interior illumination which shaped the overall appearance of the integrated complex. The lighting also created a comfortable and safe environment for the residents at night.



Farrer Square
Singapore **Mixed-use**

Lighting highlights the unique facade designs, establishing its prominence in the area and illuminating the branding aspect as well.



Indian Heritage Centre
Singapore **Civic**

Standing as a glowing beacon above the surrounding urban tapestry, this building's socio-cultural significance is highlighted through subtle and soft lighting.



Mon Jervois
Singapore **Residential**

Lighting brings out the sophistication of this residential project by accentuating its refined features.



Pollen & Bleu
Singapore **Residential**

Lighting highlights the lush landscape by creating light and shadow, forming a dramatic interplay of flora at nighttime.



Alex Residences
Singapore **Residential**

As one of the tallest buildings in the area, the lighting design accentuates the futuristic décor on the sky terrace, while highlighting the bold interplay of verdure.



V On Shenton
Singapore **Commercial**

The lighting design reflects the unique geometrical patterns on this iconic building. The scheme and lighting choice enables greater energy savings.

Interior Design

Residential or commercial, public or private, institutional or infrastructural, interior design is crucial no matter the project. From forming the heart of a home to setting the tone for a corporate or professional space, the potential of a space is realised through interior design.

Be it functionality or comfort, luxury or utility, ultimately the manner in which we conceive a space influences how it will be utilised. At ONG&ONG our interior design experience runs the gamut of typologies and scales, with award-winning projects the world over as proof of our ability to truly define any space.

Advisory & Consultancy

Feasibility Study

Master Design Guidebook

Space Planning

Test Fit

Turn Key Solutions



The Collection
Bangkok, Thailand **Residential**

Predicating the interiors and branding on four fictional characters, the Traveller, the Thinker, the Trendsetter and the Collector – personas that resonate well with the affluent modernist.



Bedok Public Library
Singapore **Institutional**

Exuding warmth through its garden-inspired furniture and fixtures and innovative wayfinding, these functional designs ensure a conducive learning place for both young and old.



Mám Concept
Ho Chi Minh City, Vietnam **Commercial**

Predicated on the flavours of the "Mám" Vietnamese taste, this three-storey narrow shophouse fuses the Vietnamese lifestyle with themes that tell a different story on every storey.



2VPG-House
Singapore **Residential**

Ritzy interiors embellish the home, creating a bespoke experience for the homeowners.



FHM Bachelor Apartment
Bangkok, Thailand **Residential**

Inspired by the social events and lifestyle of a high-flying New Yorker, the apartment is characterised by a preponderance of warm, monolithic timber walls and tinted mirrors.



KLGCC Show Gallery
Kuala Lumpur, Malaysia **Residential**

Designed as a relaxed, private golf and country club, the leisure facility incorporates state-of-the-art technologies and embodies superior facilities.



Hyatt Regency Hotel Jaipur
Jaipur, India **Hospitality**

With traditional Moorish arches and detailed stone columns, this unique Jaipur hotel houses 250 rooms and a host of amenities.



American International Hospital
Ho Chi Minh City, Vietnam **Healthcare**

Specific interiors were chosen to provide a calming environment for both patients and visitors, with clean designs that both bring the surrounding nature within and ensure a premium experience.



Hyatt Regency Riyadh
Riyadh, Saudi Arabia **Hospitality**

Based on a 'Jewel of the Desert' concept, this contemporary 257-room hotel is characterised by natural patterns and classic opulence.



Jadescape Show Gallery
Singapore **Residential**

Conceived as an extension of nature from neighbouring MacRitchie Reservoir Park and Bishan Park, Jadescape reflects an innately Oriental aesthetic.



Oakwood Suites ChongLi
ChongLi, China **Hospitality**

This resort features premium outlets and amenities, within Taizheng Village.



Sloane Residences Show Gallery
Singapore **Residential**

Replicating features of the premium residence, the fully-furnished three-bedroom show unit presents a nature-inspired modern theme, with the exact glass panes used in the development.

Masterplanning

Cities rely on experienced planners when creating infrastructure masterplans. The process of conceptualisation demands imagination and a progressive mindset.

There is a plethora of considerations, including the accessibility to services such as education and places of worship in relation to traffic flow, residential areas, lifestyle and commercial hubs. A well-designed city is future proof, able to cater to the evolving needs of its inhabitants for decades.

Vision & Strategies

Land Use Planning

Connectivity

Urban Infrastructure

Environmental Sustainability Design

Landscape



Metropolis Thao Dien
Ho Chi Minh City, Vietnam **Mixed-use**

Located along Hanoi Highway, this is an 8.2 ha master plan for a high-rise residential area combined with commercial services; the basis for a lively, exclusive community.



Kediri
Kediri, Indonesia **Mixed-use**

This plan to relocate a township of 100 ha will enable the creation of a self-sustaining boulevard with housing, schools, business and civic centres.



Vansanta Park
Bekasi, Indonesia **Mixed-use**

Envisioned as a Japanese town in Indonesia, the 12 ha of land is slated to feature 17 mixed-use towers, 217 shophouses, an 8-storey business cluster, all interconnected by 1.7 ha of parkland.



Boeung Snor
Phnom Penh, Cambodia **Mixed-use**

With the development of several high-end residential villa projects in the area, a vibrant community with civic and community activities is on the cards, improving infrastructure for this prime location.



Bataan
Bataan, Philippines **Mixed-use**

The master plan for the Bataan Provincial Capitol is undergoing major strides towards urbanism, with an integrated approach to a smart city and applying resilient design.



Ngwe Saung Beach Resorts
Myanmar **Hospitality**

A master plan comprising elegant vacation homes and exclusive amenities, this development addresses the growing demand for holiday destinations in Myanmar.



Niseko Serviced Apartments & Clubhouse
Niseko, Japan **Hospitality**

Consisting of luxury villas, private Japanese baths and a wellness centre, along with an omakase dining room and a central clubhouse, the expansive master plan further cements Niseko as a destination for the well-heeled.



Eco Glades
Selangor, Malaysia **Residential**

Eight precincts of modern eco living, with substantial land areas for open spaces, landscaping and waterscaping. The concept was derived from merging verdure with Cyberjaya's Lake Gardens, inspiring the apt name "Eco Glades"

Architecture

ONG&ONG's plethora of experience in this discipline backs every project regardless of scale or typology, enabling architectural excellence to be our stock-in-trade.

Building works of art calls for researching of the needs of users and their cultures, paired with the dedicated hands of our architects to deliver an Experience Beyond.

Masterplanning

Ideate and Create

Conceptualisation & Analysis

Research & Development

Implementation & Management



Jadescape
Singapore **Residential**

The tranquility of nearby nature parks is reflected by rich greenery and water features of the residence, offering healthy living and wellness. The building forms were made identical in height to beautify the skyline.



37FC-House
Singapore **Residential**

Intended for a multi-generational family, the four-storey structure sets the stage with verdant views and definitive materials, within a unique rectilinear design.



THK Home for Disabled @ Sembawang
Singapore **Institutional**

The needs of various patients with disabilities and Autism Spectrum Disorder (ASD) was addressed to tailor a calm and safe environment.



ALMA Resort
Nha Trang, Vietnam **Hospitality**

Set in a prime location, the retreat is accompanied by an expansive array of amenities.



Setiabakti House
Kuala Lumpur, Malaysia **Residential**

A unique blend of geometric shapes culminates into a home of luxury.



Puri Mansion
Jakarta, Indonesia **Residential**

The four residential towers introduce the concept of "riverside living", with repeated elements of interspersed staggering balconies inspired by the movement of undulating water.



Greenfield Residences
Selangor, Malaysia **Residential**

This residential development showcases sustainability within luxe living with ample modern facilities. It represents a harmonious symphony of water, greenery and style.



Eco Sanctuary Mall
Selangor, Malaysia **Commercial**

Envisaged as an appealing and holistic venue for the surrounding residents, the mall is a modern interpretation of retro suburban strip malls in the 1920s.



Nexos International School
Singapore **Education**

The new campus is sited beside an expressway and presents a dramatic facade, with its flowing form to echo vehicle movement.



Choa Chu Kang Bus Interchange
Singapore **Infrastructure**

Filled with inclusive, SMART technology, the 15,000m² facility is a breath of fresh air, supplanting its predecessor.



Park Origin Phayathai
Bangkok, Thailand **Residential**

Replete with nature's pleasures and wellness benefits, the haven tapers vertically, with terraces on selected floors.



Parque Residence
Selangor, Malaysia **Residential**

Nestled within the Eco Sanctuary township, Parkland accounts for almost half of the development's acreage, with various unit typographies and designed to visually please the brutalist design enthusiast.



Nexos International School
Singapore **Education**

The new campus is sited beside an expressway and presents a dramatic facade, with its flowing form to echo vehicle movement.



*When it comes to health and recovery, **never compromise.***

American International Hospital
Ho Chi Minh City, Vietnam
An ONG&ONG project

Inspirational Guides: Directors & Team Leaders

When it comes to the future of design, we look towards our mentors who light the way, placing their wealth of wisdom at the disposal of the team.



01



02



03



04



05



06



07



08



09



10



11



12



13



14



15



16



17



18



19



20



21



22



23



24



25



26



27

Architecture
01 Ng Cho You
02 Steven Low
03 David Ching
04 Ahmad Syazli

From Left - Right
05 Wendy Tan
Loh Kah Wai
Andrew Lee
Kurjanto Slamet

06 Lai Tien Yong
07 Ong Tze Boon
08 Diego Molina
Maria Arango
09 Hasbullah
10 Tan Kee Keat
11 Jimmy Poek
12 Goh Chong Chia
13 Robert Brodeth
14 Hoang Huu Dung
15 Lim Kok Hui
16 Ashvinkumar Kantilal
17 Tracy Loh
18 Louis Tan
19 Ong Qi Rong
20 Sunita d/o Krishna Dass
21 Erick Artavia Suarez

Interior Design
22 Raymond Thai
23 Teo Boon Kiat
24 Elli Wang
25 Kee Choon Yen
26 Chester Goh
27 Benson Wee

Wisdom, Inspiration,
Direction & Creativity.



01



02



03



04



05



06



07



08



09



10



11



12



13



14



15



16

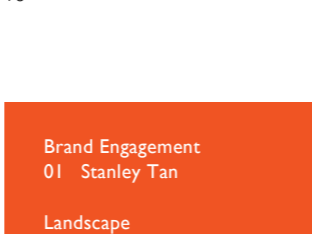

Brand Engagement

01 Stanley Tan

Landscape

02 Lena Quek

03 Huynh Thi Quoc Huong

Lighting

04 Jerome Tan

Engineering

From Left - Right

05 Richard Teo

Tan Peck Khoon

Henry Gunawan

Lim Yan Ping

David Chan

Goh Teck Sin

06 Dang Hoang Tung

07 Shahrom Bin Mohamed Ariff

08 Ryan Huynh Ngoc Nghia

09 Teh Yong Hui

Project Management

10 Thomas Yee

11 Lee Chek Shih

12 Paul Roger Lim

Administration

13 Sharon Baptist

Finance

14 Nicole Siew

Human Resources

15 Liang Lit How

Design Technology

16 Daniels Chandra

Outstanding lighting enhances spatial identification and wayfinding, creating focal points and highlighting architectural features. When dusk falls, a well-lit entrance is a visual draw. ONG&ONG's Lighting specialists ensure every project is a tailored service, constantly improving the built environment with energy-efficient brilliance.

V on Shenton
Singapore

Experience Beyond Illumination

An ONG&ONG Lighting Project
Architecture by architects61



POWER TO THE PEOPLE

THE COMMAND CENTRE

The stronghold of ONG&ONG comprises the following integrated teams. Efficiency, teamwork and strong communication all underscore the strength of our offices, enabling them to operate seamlessly across Asia.

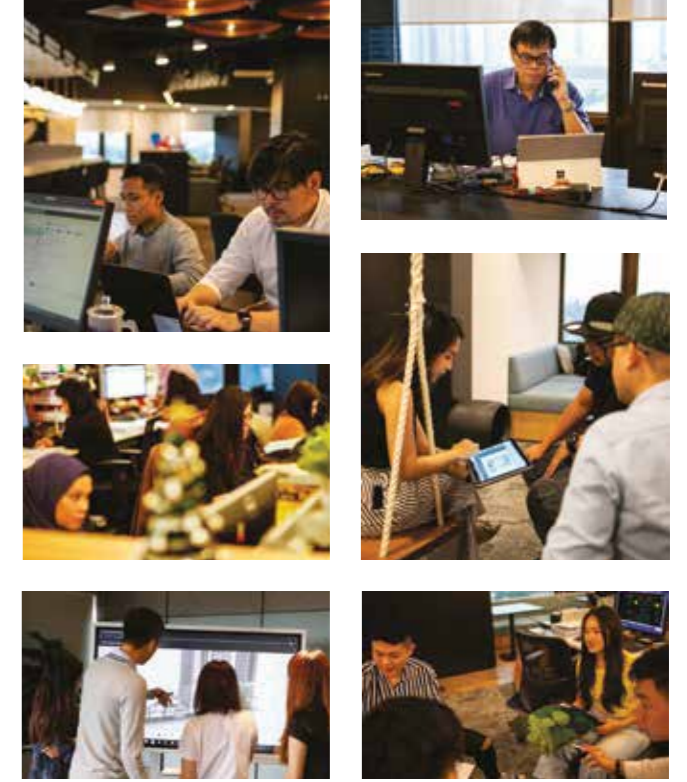

People Developers



The Office's Chiropractor



Delicate Balancers



Our Firewall



unimpeded. We envy this special breed: digital saviours possessing the art of scripting and brandishing troubleshooting skills for every IT matter.

Digital Tool Masters



Human Resource

Sun Tzu, author of The Art of War, advocated being prepared.

Keeping all offices informed of the latest business processes, Human Resource organises talks and learning programmes that constantly improve operations and self-development. They also ensure the smooth administration of personnel payroll, benefits, hiring processes and welfare.



Administration

Day-to-day operations would be impossible without them. They ensure everything at headquarters runs smoothly with facilities management, procurement and project administration.

The administrative team keeps key structures well-oiled, ensuring we operate without a hitch.

Finance

Multi-tasking is one of the prerequisites of being part of the Finance team. They handle large and complex transactions without breaking a sweat, even as they balance the books and compute numerous other financial tasks with zero discrepancy. Numbers are their forte; they are an essential chess piece for any company.

Information Technology

The computer – ubiquitous to offices, is no different here. Hopeless without functioning technology, we rely heavily on our IT team to diagnose and resolve our tech problems. Besides addressing storage issues, they have stared adversity down with a straight face, meeting the tightest deadlines. Being just a phone call away, they ensure servers remain operational and Internet access is



Design Technology

As we focus on disruptive innovation in our industry, the Design Technology team has never been more indispensable. Augmented Reality, Realtime Rendering/ VR, Integrated BIM and other technological advances like parametric design are their speciality.

While the rest of us focus on our projects, the DT team looks ahead to cutting-edge technologies that we may arm ourselves with, thereby improving

our processes. We rank amongst the forefront players in our industry, with kudos to Design Technology!



“IN OUR 360 WORLD,
WE REVISIT EXPERIENCE
DESIGN, AUGMENTED WITH
DISRUPTIVE INNOVATION.”

— Ong Tze Boon

Tan Peck Khoo
Group Chief Operating Officer

Ashvinkumar Kantilal
Group Chief Executive Officer

Ong Tze Boon
Group Executive Chairman

Orchestrating the 360 Bespoke Experience

Our world is one big marketplace. Everything is readily available, and the only thing that sets you apart from the next consultancy is an **experience beyond**. This is vastly different from “business-as-usual” as disruption now calls for a different tune to be orchestrated.

2019 has been a year of radical recalibration, **pushing our design frontiers** with cross collaborations between studios and aligning strategies.

BeyondX in July was an inaugural success, with various technology collaborators

coming aboard to showcase the latest in digital innovations for the built environment, in front of a packed audience. ONG&ONG is looking towards a brighter horizon, and in our efforts to underscore disruption, we will up the ante this 2020; inviting even more renowned speakers and being ahead in anticipating the impact of climate change.

Be quick to register for BeyondX 2020 <www.BeyondX.digital> held on 8–9 July — two days of realising our direction in the built environment. For next year, we expect a **full house** filled with thought leaders and speakers.

The earlier pages presented our overseas ventures, which spread as far as Seoul, Auckland and Birmingham (*pg. 9, 11 and 13 respectively*). We’re also keeping a keen eye on our established Asian markets, including designing the Jakarta MRT stations (*pg. 26-29*), Parque Residences, and playing a pivotal role in designing Ho Chi Minh City’s upcoming Sala City development.

Experience Design is at the core of our business, where design is a tool to deliver experiences through interactions between user and built space. Each of our projects is unique and compelling.

While other counterparts in the industry may adopt similar integrated offerings, it is the mark of a maestro to understand the rhythms of a built environment — bringing each section into perfect synchrony, crafting a superlative end-product. This unlocks the manifestation of integrated design that can stand the test of time, like our recent Sloane Residences, a premium boutique residence with a touch of GCB influence.

This is why we look toward the future where everything is in flux, from the incoming IoT, space planning, sustainability

and catering design for specific minorities; we are committed to maximising the end-user experience with our holistic 360 Solution.

With the market volatility of recent years, ONG&ONG is poised for the tidal wave of disruption. Our teams are prepared to leapfrog with industry R&D, exploiting the potential of **Artificial Intelligence** and IoT, staying ahead of each sea change, **exponentially**.

For more information on ONG&ONG and our projects, visit ong-ong.com

FINANCIAL REVIEW



Group Revenue
S\$4.4m

Group EBIT
S\$1.8m

The Group delivered resilient earnings amid heightened competition across the markets. Operating revenue remained at S\$44m. Group EBIT dropped 64% compared to FY17/18 due to our investment in co-working spaces, technology and cloud computing.

Amidst a challenging environment, the Group performed profitably. Operating revenue has remained stable. Public works continued to be the main source of income for the Singapore market, including projects for the Housing Development Board, bus depots, education campuses and MRT stations. We have also made our mark on the digital world, with involvement in wafer fabrication building and data centre projects.

Our continued efforts overseas have also enabled steady growth in the region. We believe that regional projects across Indo-China will gain greater significance in the coming years; these will, in turn, provide a revenue stream for the Group.

The growth looks promising with the revenue percentage increase in contracts secured — 114%, 56% and 224% for Indonesia, Malaysia and Thailand respectively.

The Group continues to strive for excellence. Tapping into technology and positioning itself at the forefront of disruption with BeyondX initiatives, we are poised to gain market share around Asia through the support of our regional offices.

Callary Wedding & Events
Ho Chi Minh City, Vietnam

Experience Beyond
Milestones

An ONG&ONG Project



International Consulting Company
Singapore

Experience Beyond
Workspaces

An SCA Project

OUR ORGANISATION



360 SOLUTION

ONG&ONG embraces each project's process as a singular integrated solution. We aim to form a tripartite framework consisting of design, project management and engineering solutions, to provide opportunities for cross-disciplinary interaction as well as to create coherent and sustainable designs.

Design

- Masterplanning
- Brand Engagement
- Architecture
- Experience Design
- Interior
- Landscape
- Lighting

Engineering

- Mechanical
- Electrical
- Civil
- Structural
- Environmental
- Fire Safety

Management

- Project Development
- Construction
- Cost
- Place

GLOBAL REACH



ONG&ONG
group

Singapore
China
Indonesia
Malaysia
Mongolia
Myanmar
Thailand
Vietnam

CONTACT



ONG&ONG
group

ONG&ONG Group Pte Ltd
510 Thomson Road, #11-00
SLF Building, Singapore 298135
t +65 6258 8666
f +65 6259 8648



ONG&ONG

ONG&ONG Pte Ltd
510 Thomson Road, #11-00
SLF Building, Singapore 298135
t +65 6258 8666
f +65 6259 8648
www.ong-ong.com



ONGONG360



ONG&ONG



ONGONG_360



ONGONG360



ONG&ONG

ONG&ONG Co., Ltd
Unit 1003B, Level 10
Centre Point Building
106, Nguyen Van Troi Street
Ward 8, Phu Nhuan District
Ho Chi Minh City, Vietnam
t +84 28 6285 6178 / +84 28 6285 6179
f +84 28 6285 6169

ONG&ONG 360
Consultancy Sdn Bhd
Unit 1B-08-I, Blok 1B, Plaza Sentral
Jalan Stesen Sentral 5
50470 Kuala Lumpur, Malaysia
t +60 3 2272 2360
f +60 3 2272 3360

ONG&ONG (Chengdu) Consultants
Co. Ltd
Unit 802, 8F, Tower 1, Raffles City Chengdu
No.3, Section 4, South Renmin Road, Chengdu
610041, People's Republic of China
t +86 28 6510 0866
f +86 28 6510 0868

ONG&ONG (Chengdu) Consultants
Co. Ltd - Shanghai
3E, 3rd Floor, Block 19
322 Jiaozhou Road, Jing An District
Shanghai, 200040
People's Republic of China
t +86 21 6381 5800
f +86 21 5273 521

ONG&ONG Design LLC
Residence 60, 4th Khoroo,
15th Khoroolol Peace Auv 8B, Ulaanbaatar,
Mongolia 13345
t +976 7575 6515
f +976 7575 6525

PT ONG and ONG
Grha Niaga Thamrin 1st Floor Unit A1
Jl. K.H. Mas Mansyur
Kebon Melati, Tanah Abang
Jakarta Pusat -10230 Indonesia
t +62 21 2139 2269
f +62 21 2139 2309

ONG&ONG Limited
No 45/5 Unit-A, Kabar Aye Pagoda Road,
9th Ward Mayangone T/S,
Yangon, Myanmar
t +95 97822 25714

ONG&ONG Design Co., Ltd
75 / 39 Level 12A Richmond Office Building
Sukhumvit Soi 26, Klongton, Klongtoey
Bangkok 10110, Thailand
t +66 2259 8917-8



Project Innovations Pte Ltd
510 Thomson Road
#09-00 SLF Building
Singapore 298135
t +65 6255 3966
f +65 6255 5966
www.proj-innovations.com



Project X:ion Pte Ltd
510 Thomson Road
#09-00 SLF Building
Singapore 298135
t +65 6255 3966
f +65 6255 5966
www.proj-xion.com



Rankine&Hill
(Singapore) Pte Ltd
510 Thomson Road
#09-00 SLF Building
Singapore 298135
t +65 6278 9588
f +65 6273 5290 (M&E)
f +65 6339 9313 (C&S)
www.rankine-hill.com

Rankine&Hill
(Vietnam) Co., Ltd
Unit 1003B, Level 10
Centre Point Building
106, Nguyen Van Troi Street
Ward 8, Phu Nhuan District
Ho Chi Minh City, Vietnam
t +84 28 6285 6178 / +84 28 6285 6179
f +84 28 6285 6169

Rankine&Hill Sdn Bhd
Unit 1B-08-I, Blok 1B, Plaza Sentral
Jalan Stesen Sentral 550470
Kuala Lumpur, Malaysia
T +60 3 2272 2360 F +60 3 2272 3360

Rankine & Hill (Myanmar) Limited
No 45/5 Unit-J3, Kabar Aye Pagoda Road,
9th Ward Mayangone T/S,
Yangon, Myanmar



SCA Design Pte Ltd
510 Thomson Road
#09-00 SLF Building
Singapore 298135
t +65 6253 4886
f +65 6255 4568
www.sca-design.com

IMMORTAL
Brand Engagement

IMMORTAL
The Design Station Pte Ltd
510 Thomson Road,
#09-00 SLF Building
Singapore 298135
t +65 6227 9406
f +65 6259 8648
www.immortal.com.sg



ImmortalSingapore



Immortal_SG



ImmortalSG



Experience Beyond Dwelling

An ONG&ONG Project

OUR WINNING STREAK 2019



Commonwealth Lane: Death & The Community
Landscape
World Architecture Festival, Finalist



American International Hospital
Interior Design
Inside Festival Finalist



Bedok Public Library
Architecture and Interior Design
Inside Festival Finalist



Heartbeat@Bedok
Architecture, Landscape, Lighting and M&E Engineering
Good Design Awards



West Rock @ Bukit Batok
Architecture, Landscape, C&S Engineering and M&E Engineering
BCA Universal Design Mark Awards, GoldPlus



Ulu Pandan Bus Depot
Architecture and M&E Engineering
BCA Construction Productivity Awards, Gold

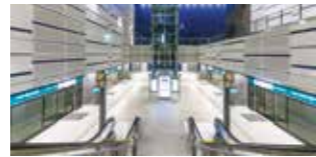

Downtown Line Kaki Bukit MRT Station
Architecture
BCA Construction Excellence Awards, Excellence



Tampines Green Foliage
Architecture and Landscape
BCA Universal Design Mark Awards, GoldPlus



Sembawang Sun Breeze
Architecture, C&S Engineering and M&E Engineering
BCA Green Mark Awards, GoldPlus



Heartbeat@Bedok
Architecture, Landscape, Lighting and M&E Engineering
BCA Universal Design Mark Awards, GoldPlus

BCA Construction Excellence Awards, Merit



Al-Ansar Mosque
Architecture
Asia Pacific Property Awards, Singapore Award Winner



Bedok Public Library
Architecture
Asia Pacific Property Awards, Singapore Award Winner



Jadescape
Architecture
Asia Pacific Property Awards, Singapore Award Winner

International Property Awards Nominee



Grandezza, Eco Sanctuary
Architecture
Asia Pacific Property Awards, Malaysia Award Winner

International Property Awards Nominee



Mass Rapid Transport (MRT) Line 2
Architecture
Asia Pacific Property Awards, Malaysia Award Winner



Mám Concept
Interior Design
Asia Pacific Property Awards, Vietnam Award Winner



American International Hospital
Interior Design
Asia Pacific Property Awards, Vietnam Award Winner



Gold Coast Sea View Apartment
Architecture, Interior Design and Landscape
Asia Pacific Property Awards, Indonesia Award Winner



American International Hospital
Interior Design
WIN Awards, Healthcare and Clinic Category, Gold



Bedok Public Library
Architecture and Interior Design
WIN Awards, Learning Category, Finalist



360 Circle Publication
Brand Engagement
Singapore Good Design



FBN Asia, 10th Anniversary Commemorative Book
Brand Engagement
Singapore Good Design



PS Skin Packaging
Brand Engagement
Singapore Good Design



Toomato Italian Kitchen
Brand Engagement
Singapore Good Design



Bedok Public Library
Architecture and Interior Design
Singapore Good Design



BeyondPak
Human Resource in collatration with NYP's School of Design
Singapore Good Design



Jurong Central Plaza
Architecture, C&S Engineering and M&E Engineering
HDB Design Awards, Rejuvenation category, Certificate of Merit



West Rock @ Bukit Batok
Architecture, Landscape, C&S Engineering and M&E Engineering
HDB Design Awards, Construction category



ONG&ONG Pte Ltd
BCI Top 10 Architects, Singapore



ONG&ONG Group Pte Ltd
ONG&ONG Holding Pte Ltd
ONG&ONG Pte Ltd
Singapore SME 1000 Company



MacPherson MRT Station
Architecture
Land Transport Excellence Award, Project Partner Award



Heartbeat@Bedok
Architecture, Landscape, Lighting and M&E Engineering
SILA, Silver



West Rock @ Bukit Batok
Architecture, Landscape, C&S Engineering and M&E Engineering
SILA, Silver



Frasers Tower
Landscape
SILA, Merit



Parque Residences
Architecture
Cityscape Awards, Special Commendation



Greenfield Residence @ Bandar Sunway
Architecture
PropertyGuru Malaysia Property Awards, Best Mid End Condo, Highly Commended



Jadescape
Architecture
PropertyGuru Singapore Property Awards:

Best Mega Scale Condo Development, Highly Commended

Best Mega Scale Condo Architectural Design, Winner

Best Mega Scale Condo Landscape Architectural Design, Winner

Best Smart Building Development, Winner



Sloane Residences
Architecture and Landscape
PropertyGuru Singapore Property Awards:

Best Boutique Condo Development (Low Density), Winner

Best Boutique Condo Architectural Design, Winner

Best Boutique Condo Interior Design, Highly Commended



Jurong West Street 52 Nursing Home
Architecture, C&S Engineering and M&E Engineering
BIM Award by MOHH

OUR WINNING STREAK 2018



Empire City Show Gallery
Interior Design
Asia Pacific Property Awards, Vietnam Award Winner

Parque Residences
Architecture
Asia Pacific Property Awards, Malaysia Award Winner



Heartbeat@Bedok
Architecture, Landscape, Lighting and M&E Engineering
Asia Pacific Property Awards, Singapore Award Winner

Asia Pacific Mixed-use Architecture, Nominee



Monterey Residences
Architecture
International Property Awards, Asia Pacific Award Winner

Asia Pacific Property Awards, Malaysia Award Winner



Senturia Vuon Lai
Landscape
Asia Pacific Property Awards, Vietnam Award Winner



Sala Sarica
Architecture, Interior Design, Landscape, C&S and M&E Engineering
Asia Pacific Property Awards, Vietnam Award Winner



Empire City Show Gallery
Interior Design
Asia Pacific Property Awards, Vietnam Award Winner



The Scotts Tower by Far East Organization
Architecture
Asia Pacific Property Awards, Singapore Award Winner



Senturia An Phu
Landscape
PropertyGuru Vietnam Property Awards, Best Housing Landscape Architectural Design, Highly commended



One Verandah
M&E Engineering
PropertyGuru Vietnam Property Awards:

Best High End Condo Architectural Design, Winner

Best High End Condo Landscape Architectural Design, Highly commended



RichLane Residences by Mapletree
Interior Design
PropertyGuru Vietnam Property Awards, Best High End Condo Development (Ho Chi Minh City), Highly commended



Park Origin Phayathai
Architecture
PropertyGuru Thailand Property Awards:

Best Luxury Condo Development (Bangkok), Highly commended

Best Condo Landscape Architectural Design (Bangkok), Highly commended

Best Luxury Condo Architectural Design (Bangkok), Highly commended



Senturia Vuon Lai
Landscape
PropertyGuru Vietnam Property Awards:

Best Housing Landscape Architectural Design, Highly commended

Best Housing Development (Ho Chi Minh City), Winner



Jadescape
Architecture, Interior Design and M&E Engineering
PropertyGuru Singapore Property Awards:

Best Universal Design Development

Best Private Condo Development

Best Private Condo Interior Design Hospitality, Finalist



Gem Riverside
Architecture
PropertyGuru Vietnam Property Awards, Best Condo Landscape Architectural Design, Highly commended



Heartbeat@Bedok
Architecture, Landscape, Lighting and M&E Engineering
World Architecture Festival, Finalist



Ocean Gate Nha Trang
Interior Design
BCI Asia Interior Design Awards



Faber-House
Architecture
A' Design Awards, Residential Home Category, Gold Winner



KAP-House
Architecture
A' Design Awards, Residential Home Category, Gold Winner



ONG&ONG Pte Ltd
BCI Top 10 Architects, Singapore



GIC Pte Ltd
Interior Design
BCA Green Mark Awards, Platinum for Office Interior



Le Quest
Interior Design and M&E Engineering
BCA Green Mark Awards, GoldPlus



Singapore Sustainability Academy
Architecture and M&E Engineering
BCA Green Mark Awards, Platinum



Downtown MRT Line, comprising of Mattar Station, MacPherson Station, Ubi Station, Kaki Bukit Station & Bedok North Station
Architecture
BCA Construction Productivity Awards (Civil Engineering Projects), Platinum

BCA Construction Excellence Awards (Civil Engineering Projects Category)



Katong Square
Architecture
BCA Construction Excellence Awards



Downtown Line Tampines East Station
Architecture
BCA Design and Engineering Safety Excellence Awards (Civil Engineering) – Merit



Mám Concept
Interior Design
Architizer A+ Awards 2018, Unbuilt

Hospitality, Finalist



ONG&ONG
DOTY, Designer of the Year



Setia Eco Glades
Architecture and Masterplanning
FIABCI World Prix d'Excellence Awards, Masterplanning Category



Bishopsgate House
Architecture
The Architecture MasterPrize, Honorable Mention



Yishun Nature Park
Architecture and Landscape
IFLA AAPME (Wildlife, Biodiversity, Habitat Enhancement or Creation Category), Award of Excellence



Gateway Theatre
Architecture, Landscape, Lighting and M&E Engineering
The International Architectural Awards, Winner



KAP-House
Architecture
The International Architectural Awards, Winner



The Scotts Tower by Far East Organization
Architecture
Singapore Good Design Mark



The Scotts Tower by Far East Organisation
Architecture
MIPIM Asia Awards, Best Residential Development, Bronze Winner



Eco Sanctuary
Architecture
Star Property Awards, Cornerstone Award



ONG&ONG Group Pte Ltd
ONG&ONG Holding Pte Ltd
ONG&ONG Pte Ltd
Singapore SME 1000 Company

beyond+

Terashi
Solar-powered lamp



When all other lights go out
shop.beyond-allthings.com

LIVE
LEARN
CREATE.

Live responsibly and assist our fellow global citizens
Collective knowledge to exact positive change
Innovate sustainable solutions for a better tomorrow



Guiding young leaders into the future, ONG Foundation continues to inspire and motivate talented individuals with climbs to The Ong Teng Cheong Peak (4,743m) in Kazakhstan and The Ong Siew May Peak (4,451m) in Kyrgyzstan.

The mountaineering teams from the National University of Singapore (NUS) and Singapore University of Technology and Design (SUTD) attempted to summit the two peaks in mid-2019. But as with life, the weather was unpredictable, throwing curve balls that hindered summiting.

The experience tested participants on their perseverance, and a true-life lesson on keeping a clear head and adapting to changing situations. ONG Foundation aims to continue to mould these promising leaders into worldly individuals committed to improving society and realising a brighter future for their communities.

Image credit: Teddy Hartanto, NUS Mountaineering

ongfoundation.org

ONG FOUNDATION

EXPERIENCE
BEYOND.

WE UNDERSTAND ASIA

SINGAPORE CHINA INDIA INDONESIA MALAYSIA MONGOLIA MYANMAR PHILIPPINES THAILAND VIETNAM

ong-ong.com